

POLE ATTACHMENT AGREEMENT

DATED 4/9/2004

BETWEEN

VERIZON NEW ENGLAND INC. (LICENSOR)

AND

PUBLIC SERVICE COMPANY OF NEW HAMPSHIRE, (LICENSOR)

AND

FREEDOM RING COMMUNICATIONS, LLC. d/b/a Bayring
Communications, (LICENSEE)

TABLE OF CONTENTS

1.	DEFINITIONS	3
2.	SCOPE OF AGREEMENT	5
3.	FEES AND CHARGES	6
	3.1 General	6
	3.2 Attachment Fees	7
	3.3 Pre-construction Survey, Make-ready and Inspection Charges	7
	3.4 Payment Requirements	8
	3.5 Billing Disputes	9
4.	APPLICATION FOR AND ISSUANCE OF LICENSES	10
5.	PRE-CONSTRUCTION SURVEY and MAKE-READY WORK	10
6.	SPECIFICATIONS AND LEGAL REQUIREMENTS	11
7.	CONSTRUCTION AND MAINTENANCE OF ATTACHMENTS	12
	7.1 General Provisions	12
	7.2 Licensee's Routine Maintenance, Overlash, Rebuild Work and Placement of Power Supplies	14
8.	INSPECTION OF LICENSEE'S FACILITIES	14
9.	UNAUTHORIZED ATTACHMENTS	16
10.	TERMINATION	16
	10.1 60-Day Termination	16
	10.2 Immediate Termination	17
	10.3 General	17
	10.4 Licensee's Removal of Attachments	18
11.	ASSIGNMENT OF RIGHTS	18
12.	SURETY REQUIREMENTS	19
13.	LIABILITY AND DAMAGES	19
14.	INSURANCE	21
15.	GENERAL PROVISIONS	22
	15.1 Authorization Not Exclusive	22
	15.2 Failure to Enforce	23
	15.3 Notices	23
	15.4 Severability	23
	15.5 Choice of Laws	23
	15.6 Compliance with Laws	24
	15.7 Survival	24
	15.8 Use of Information	24
	15.9 Access to Records	24
	15.10 Dispute Resolution	24
	15.11 Emergency Conditions	25
16.	TERM OF AGREEMENT	25
	APPENDICES	27

POLE ATTACHMENT AGREEMENT

THIS AGREEMENT, made as of this 9th day of APRIL 2004, between VERIZON NEW ENGLAND INC. organized and existing under the laws of the State of New York, having its principal office at 185 Franklin Street, Boston, MA 02110, and PUBLIC SERVICE COMPANY OF NEW HAMPSHIRE, organized and existing under the laws of the State of NH, having its principal office at Manchester (either or both hereinafter called "Licensor") and FREEDOM RING COMMUNICATIONS, LLC. d/b/a BAYRING COMMUNICATIONS, organized and existing under the laws of the State of New Hampshire, having its principal office at Portsmouth, NH (hereinafter called "Licensee").

WITNESSETH

WHEREAS, Licensee for its own use desires to place and maintain cables, equipment, and facilities on poles of Licensor, specifically in the State/Commonwealth of New Hampshire; and

WHEREAS, Licensor is willing to permit, to the extent it may lawfully do so, the placement of cables, equipment, and facilities by Licensee on Licensor's poles subject to the terms of this Agreement;

NOW, THEREFORE, in consideration of the mutual covenants, terms and conditions herein contained, the parties agree as follows:

ARTICLE I - DEFINITIONS

- 1.1 Anchor. A facility consisting of an assembly of a rod secured to a fixed object or plate designed to resist the pull of guy strand, or strands.
- 1.2 Anchor Attachment. A guy strand attached to an anchor solely owned or jointly owned by Licensor or for which Licensor is responsible for authorizing attachments.
- 1.3 Attachments. Any of Licensee's facilities in direct contact with or supported by a utility pole, and/or any article of equipment attached to a point on a pole not normally occupied by a strand attachment (e.g., power supplies, equipment, cabinets, terminals, etc.). For billing purposes an Attachment is counted for each guy strand and cable supported by a through-bolt and for each article of equipment attached to a Utility Pole.

- 1.4 Attachment Fee. A specified amount revised periodically, billed semi-annually or annually to the Licensee.
- 1.5 Guy Strand. A metal cable of high tensile strength which is attached to a pole and anchor or another pole for the purpose of reducing pole stress.
- 1.6 Joint Owner. A person, corporation or other legal entity having an ownership interest in a pole and/or anchor.
- 1.7 Joint User. A party to whom use of the pole or anchor has been extended by the owner of the facility. The term "Joint User" shall not include Licensees.
- 1.8 Licensee's Facilities. The cable and all associated equipment and hardware owned by the Licensee.
- 1.9 Licensee's Maintenance Work. Work performed by Licensee on its facilities and attachments for repair, replacement and daily servicing of its plant, not associated with any significant overlash or rebuild project.
- 1.10 Make-ready Work. All work, including, but not limited to rearrangement and/or transfer of existing facilities, replacement of a pole or any other changes required to accommodate the attachment of licensee's facilities to a pole or anchor.
- 1.11 Overlash – The act of attaching any single strand, hardware, cable, wires and/or apparatus owned by Licensee to same Licensee's existing strand, hardware, cable, wires and/or apparatus.
- 1.12 Periodic Inspection. Licensor's inspection of Licensee's facilities performed to determine that attachments are authorized and are maintained in conformance with the required specifications in Article VI of this Agreement.
- 1.13 Planning Manager's Area. A geographic area assigned to a Verizon New England Engineer representative. The Planning Manager's Areas are set forth in APPENDIX III.
- 1.14 Pre-construction Survey. There are two elements of the Pre-construction Survey: 1.) field inspection of the existing pole and anchor facilities to determine any necessary Make-ready Work, and 2.) administrative effort required to process the application and to prepare the charges for Make-ready Work, if applicable.

- 1.15 Post-construction Inspection. Inspection performed to measure and/or to visually observe Licensee's Facilities, during or shortly after completion of construction to ensure the attachment and the installation of the Licensee's Facilities conform to the standards required by this Agreement.
- 1.16 Rebuild. Work other than Licensee's Maintenance Work performed by Licensee to replace, add to or alter its existing attachments or facilities attached to Licensor's poles.
- 1.17 Subsequent Inspections. Inspections performed to confirm the correction of non-conforming conditions, which were observed during Periodic or Post-construction Inspections.
- 1.18 Suspension Strand (Messenger). A metal cable of high tensile strength attached to a pole and used to support facilities.
- 1.19 Unit Cost. A dollar amount subject to periodic revision by Licensor, associated with Pre-construction Surveys, Make-ready Work and Inspections applicable to specific work operations and functions.
- 1.20 Utility Pole. A pole solely owned, jointly owned, or jointly used by the Licensor and used to support its facilities and/or the facilities of an authorized Licensee.

ARTICLE II – SCOPE OF AGREEMENT

- 2.1 Subject to the provisions of this Agreement, Licensor agrees to issue to Licensee for any lawful purpose, revocable, non-exclusive licenses authorizing the attachment of Licensee's Facilities to Licensor's poles. This Agreement governs the fees, charges, terms and conditions under which Licensor issues such licenses to Licensee. Licensee must obtain separate authorization from, and pay all applicable Fees and Charges to, each Licensor and any Joint Owner or Joint User of any Utility Pole. This Agreement is not in and of itself a license, and before making any attachment to any Utility Pole, Licensee must apply for and obtain a license.
- 2.2 This Agreement supersedes all previous aerial agreements between Licensor and Licensee. This Agreement shall govern all existing licenses between Licensee and Licensor as well as all licenses issued subsequent to execution of this Agreement.

- 2.3 No use, however extended, of Licensor's pole or payment of any fees or charges required under this Agreement shall create or vest in Licensee any ownership or property rights in such poles. Licensee's rights herein shall be and remain a license.
- 2.4 Nothing contained in this Agreement shall be construed to require Licensor to construct, retain, extend, place, or maintain any pole or other facilities not needed for Licensor's own service requirements.
- 2.5 Nothing contained in this Agreement shall be construed as a limitation, restriction, or prohibition against Licensor entering into agreements with other parties regarding the poles covered by this Agreement. The rights of the Licensee shall at all times be subject to any existing agreement(s) or arrangement(s) between Licensor and any Joint Owner(s) or Joint User(s) of Licensor's poles.
- 2.6 Nothing contained in this Agreement shall be construed to require Licensor to grant a license where Licensor believes that placement of Licensee's Facilities would interfere with Licensor's existing service requirements, or the use of Licensor's facilities by other parties, or create a hazardous or unsafe condition.

ARTICLE III – FEES AND CHARGES

3.1 General

- 3.1.1 Licensee agrees to pay to Licensor the applicable Attachment Fees and Charges as specified in and in accordance with the terms and conditions of subpart 3.2 of this Agreement and of APPENDIX I, attached hereto and made a part hereof.
- 3.1.2 The Licensor may change the amount of Attachment Fees and Charges specified in APPENDIX I by giving the Licensee not less than sixty (60) days written notice prior to the date the change is to become effective. Notwithstanding any other provision of this Agreement, Licensee may terminate this Agreement at the end of such sixty (60) day notice period if the change in Fees and Charges is not acceptable to Licensee.

In order to terminate in this circumstance the Licensee must give Licensor written notice of its election to terminate this Agreement at least thirty (30) days prior to the end of such sixty (60) day notice period or for such other period as the parties may agree in writing. Licensee shall thereafter remove its facilities and attachments in accordance with the process set forth in Article X, subpart 10.3 of this Agreement.

- 3.1.3 Changes in the amount of Attachment Fees and Charges specified in APPENDIX I shall become effective on the date specified by Licensor, subject to the sixty (60) day advance written notice. The changes shall be presumed acceptable unless at least thirty (30) days prior to the end of the sixty (60) day notice period Licensee advises Licensor in writing that the changes are unacceptable and, in addition, submits the issue to the regulatory body asserting jurisdiction over this Agreement for decision. Licensee shall pay the existing Attachment Fees and Charges during the time that the issue is being reviewed by said regulatory body, subject to true-up based on the final determination of rates by said regulatory body plus any interest prescribed by said regulatory body.

Licensor shall provide licensee with an updated APPENDIX I following the effective date of the new Attachment Fees and Charges.

3.2 Attachment Fees

- 3.2.1 Licensees shall pay an Attachment Fee for each attachment made to Licensor's Utility Poles. For the purpose of computing the Attachment Fees due hereunder, the Fee shall be based upon the number of attachments for which licenses have been issued.
- 3.2.2 Attachment Fees are calculated from the first day of the month following the date a license is issued. Fees shall be payable semi-annually or annually in advance, unless otherwise provided. Payment is due within the later of thirty (30) days from the first day of January and the first day of July or thirty (30) days from the date the bill is issued.

3.3 Pre-construction Survey, Make-ready Work and Inspection Charges

- 3.3.1 Licensee shall calculate and pay to Licensor the applicable Pre-construction Survey Charge with its License Application. The License Application forms are set forth in APPENDIX IV, attached hereto and made a part hereof. The Pre-construction Survey Charge shall be calculated based on the rates and formulas set forth in APPENDIX I.
- 3.3.2 Except as provided in Appendix VI, Licensee shall make an advance payment of the applicable Charge to Licensor prior to any performance by Licensor of any Pre-construction Survey, Make-ready Work, Post-construction Inspection or Subsequent Inspection. Where the work to be performed by Licensor is covered by a Unit Cost as described in subpart 3.3.4, the Licensor shall use the Unit Cost for the Charge. Where the work

to be performed by Licensor is not covered by a Unit Cost, in whole or in part, the Charge will be based on an estimate of charges. For any charges based on an estimate, the Licensee shall be credited for any amount paid in excess of the Licensor's estimated charges, or shall be billed for any amount in addition to Licensor's estimated charges, as compared to the actual charges as finally computed.

3.3.3 Licensee shall make payment to the Licensor within thirty (30) days following the invoice for Periodic Inspections according to subpart 3.3.4 of this Agreement.

3.3.4 Pre-construction Survey, Make-ready Work, and Inspection (Post-construction Inspection, Periodic Inspection and Subsequent Inspection) Charges are based upon Unit Costs, where available. Unit Costs are set forth in APPENDIX I of this Agreement and are subject to change from time to time; provided however, the Unit Costs shall not change more frequently than once every twelve (12) months. Any changes in Unit Cost shall not vary by more than five percent (5%) per annum from the existing Unit Cost; provided that in the case of a significant and unforeseen change in circumstances affecting Licensor's costs, Licensor may adjust Unit Cost in excess of 5%. Sixty (60) days prior to any change in Unit Cost in excess of 5%, Licensor shall provide to Licensee a written explanation of the significant and unforeseen change in circumstance for the increase. A significant and unforeseen change in circumstances affecting Licensor's costs include changes in tax laws, accounting changes, and regulatory, judicial or legislative changes that affect the Licensor's costs. A statement of current Unit Costs are set forth in APPENDIX I and changes thereto shall be published at the time of such change.

For work where Unit Costs are not available, such as cable splicing, such costs will be billed on an actual time and material basis plus an amount equal to ten percent (10%) of such costs.

3.4 Payment Requirements

3.4.1 For any bill rendered by Licensor to Licensee hereunder, except where advance payment is required, payment is due within thirty (30) days from the date of the bill. Late payment of any bill is subject to a late fee of 1.5% per month applied to the outstanding balance from the due date of the bill. Licensor, at its sole discretion, may change this late fee from time to time during the term of this Agreement to reflect prevailing market conditions.

- 3.4.2 Non payment of any amount due hereunder shall constitute a default of this Agreement, and subject this Agreement to termination under the provisions of Article X.
- 3.4.3 For any bill rendered by Licensor to Licensee for advance payment of Pre-construction Survey Charges or Make-ready Work Charges, hereunder, payment shall be made within thirty (30) days of the bill date. If such advance payment is not received within thirty (30) days, Licensor shall have the right to issue a letter of cancellation no sooner than 15 days thereafter, which will cancel the Licensee's application for the license. Thereafter, if Licensee wishes to proceed, Licensee shall submit a new application for a license, as if it had never submitted the initial application.

3.5 Billing Disputes

- 3.5.1 Where Licensee in good faith disputes a bill or invoice rendered by Licensor, Licensee shall make payment of all portions of said bill or invoice not in dispute as provided in Article III. Where the cumulative amount of all of Licensee's bills or portions(s) of bills in dispute are in excess of \$10,000.00, Licensee shall deposit said cumulative disputed amounts in an interest-bearing escrow account until such time as the disputes are resolved. The disputed amount deposited together with the proportional interest, shall be distributed immediately to Licensor and/or Licensee in accordance with and upon resolution of the dispute. Where the cumulative amount of all of Licensee's bills or portions of bills in dispute are less than or equal to \$10,000.00, Licensee shall make payment to Licensor and shall be rebated an appropriate amount (including interest computed at the prime rate at a bank mutually agreed to by the parties) based on the resolution of the dispute.
- 3.5.2 Where Licensee fails to pay an amount due and owing under this Agreement (including amounts in dispute that are less than or equal to \$10,000) or fails to establish an escrow account for disputed amounts more than \$10,000, or fails to invoke the dispute-resolution procedures set forth in subpart 15.10 of this Agreement within six months of the establishment of amounts disputed in good faith, in addition to all other remedies available to Licensor including termination under provisions of Article X of this Agreement, Licensor may refuse to perform any Survey, Inspection or Make-ready Work for Licensee and may refuse to issue any license to Licensee until such time as the amount is paid or is deposited in an escrow account.

ARTICLE IV - APPLICATION FOR AND ISSUANCE OF LICENSES

- 4.1 Before Licensee makes an Attachment to any pole, Licensee shall make application for and have received a license therefor in the forms attached in APPENDIX IV. Licensor may update these forms from time to time during the term of the Agreement.
- 4.2 Licensee agrees to limit the filing of applications for pole attachment licenses to include not more than 200 poles on any one application. Licensor reserves the right to limit the filing for pole attachments to no more than 2,000 poles on all applications that are pending approval by Licensor at any one time within a single Planning Manager's Area. Licensee further agrees to designate a desired priority of completion of the Pre-construction Survey and Make-ready Work for each application relative to all other of its applications on file with Licensor at the same time.
- 4.3 Properly completed license applications received by Licensor on the same day from two or more licensees for attachment accommodations on the same pole(s), shall be processed together. All Pre-construction Survey or Make-ready Work required to accommodate the applicants will be completed simultaneously for the benefit of all applicants. All applicants will be rebated with the pro rata share of costs based on the number of applicants.

ARTICLE V – PRE-CONSTRUCTION SURVEY and MAKE-READY WORK

- 5.1 A Pre-construction Survey is required for each pole and anchor for which an attachment is requested to determine the adequacy of the pole and anchor to accommodate Licensee's attachments and facilities. The Pre-construction Survey will be performed jointly by representatives of Licensor, Joint Owner and/or Joint User, and Licensee unless otherwise agreed to by all parties.
- 5.2 Licensor will process all requests for access to poles on a non-discriminatory basis in the order such requests are received.
- 5.3 Within forty-five (45) days of receipt of written notification in the form of a complete license application and the correct Survey Fee payment, Licensor shall perform or have performed a Pre-construction Survey and present the Survey results. The Survey results will contain one of the following statements:

If no Make-ready Work is required, a license shall be issued for the attachment.

If Licensor determines that the pole or anchor to which Licensee desires to make attachments is inadequate or otherwise needs rearrangement of the existing facilities thereon to accommodate the Licensee's Facilities, in accordance with the specifications set forth in Article VI, Licensor will provide Licensee with an itemized invoice for such anticipated Make-ready Work. The Make-ready Work will be performed following receipt by Licensor of advance payment, but not before a Pole Attachment Agreement has been fully executed by both the Licensee and Licensor. Upon receipt of the advance payment, Licensor will provide the Licensee with the estimated start and estimated construction completion date of the Make-ready Work.

If Licensor determines that the pole may not reasonably be rearranged or replaced to accommodate Licensee's Facilities for reasons of capacity, safety, reliability or engineering, the Licensor may refuse to grant a license for attachment. Licensor shall provide the specific reason(s) for such denial. Licensor shall not unreasonably exercise the right reserved hereunder.

- 5.4 Licensor shall make every reasonable effort to complete Make-ready Work within six (6) months of receipt of payment for Make-ready Work from Licensee, except for reasons beyond Licensor's control. For applications consisting of six (6) or fewer poles requiring Make-ready Work, and where Verizon is the only party required to perform make-ready work, Verizon will complete the make-ready work within 45 days.
- 5.5 To the extent practicable, Licensor shall provide Licensee, no less than sixty (60) days prior written notice of any modification of poles (such as pole replacement or relocation) other than routine maintenance, or modifications in response to emergencies, or to a request from a governmental authority.

ARTICLE VI - SPECIFICATIONS AND LEGAL REQUIREMENTS

- 6.1 Licensee's Facilities shall be placed and maintained in accordance with the requirements and specifications of the latest editions of the "Blue Book - Manual of Construction Procedures" (Blue Book), published by Telcordia Technologies Inc.; the "National Electrical Code" (NEC), published by the National Fire Protection Association, Inc.; the "National Electrical Safety Code" (NESC), published by the Institute of Electrical and Electronics Engineers, Inc.; and rules and regulations of the U.S. Department of Labor issued pursuant to the "Federal Occupational Safety and Health Act of 1970", as amended, (OSHA) or any governing authority having jurisdiction over the subject matter. Where a difference in specifications may exist, the more stringent shall apply.
- 6.2 Licensee shall be responsible for obtaining from the appropriate public and/or private authority any required authorization to construct, operate and/or maintain

Licensee's Facilities on public and private property at the location of Licensor's poles. Licensee shall be responsible for obtaining permission from any Joint Owner(s) or Joint User(s) of the pole before making any attachment thereto. This permission shall be in the form of a license or other writing.

- 6.3 No license granted under this Agreement shall extend to any of the Licensor's poles where the placement of Licensee's attachments would result in a forfeiture of the rights of licensor, Joint Owner(s), or Joint User(s) to occupy the property on which such poles are located. If placement of Licensee's attachments would result in a forfeiture of the rights of licensor, Joint Owner(s), or Joint User(s) or both, to occupy such property, Licensee agrees to remove its attachments forthwith; and Licensee agrees to pay Licensor, Joint Owner(s) or Joint User(s), or both all losses, damages and costs incurred as a result thereof.

ARTICLE VII - CONSTRUCTION AND MAINTENANCE OF ATTACHMENTS

7.1 General Provisions

- 7.1.1 Licensee shall, at its own expense, construct and maintain its attachments and facilities on Licensor's poles in a safe condition and in a manner acceptable to Licensor. Licensee shall construct and maintain its attachments and facilities so as not to conflict with the use of Licensor's poles by Licensor or by other authorized users of Licensor's poles, nor electrically interfere with Licensor's facilities attached thereto.
- 7.1.2 Licensor shall specify the point of attachment on each of Licensor's poles to be occupied by licensee's attachment. Where multiple Licensees' attachments are involved, Licensor shall attempt, to the extent practical, to designate the same relative position on each pole for each Licensee's attachments.
- 7.1.3 Licensee shall provide written notice to the Licensor of the actual dates of attachment within thirty (30) days of the date of attachment so that Licensor may promptly schedule a Post-construction Inspection.
- 7.1.4 Licensee may attach its guy strand to Licensor's existing anchor rod at no charge where Licensor determines that adequate capacity is available; provided that Licensee agrees to secure any necessary right-of-way therefor from the appropriate property owner. Should Licensor, Joint Owner(s) or Joint User(s), if any, for its own service requirements, need to increase its load on the anchor rod to which Licensee's guy is attached,

Licensee will either arrange its guy strand on the anchor rod or transfer it to a replacement anchor as determined by Licensor.

- 7.1.5 Should Licensor, Joint Owner(s), Joint User(s), or other Licensee need to attach additional facilities to any of Licensor's poles, to which Licensee is attached, Licensee will either rearrange its attachments on the pole or transfer them to a replacement pole as determined by Licensor so that the additional facilities of Licensor, Joint Owner(s) Joint User(s) or other Licensee may be attached.
- 7.1.6 If Licensee does not rearrange or transfer its attachments within fifteen (15) days after receipt of written notice from Licensor requesting such rearrangement or transfer and indicating that such pole is ready for rearrangement or transfer by Licensee, Licensor, Joint Owner(s) or Joint User(s) may perform or have performed such rearrangement or transfer, and, notwithstanding the provisions of subpart 7.1.7, Licensee agrees to pay the cost thereof.
- 7.1.7 Licensee shall not be required to bear any of the costs of rearranging or replacing its attachment if such rearrangement or replacement is necessitated solely as a result of an additional attachment or modification of an existing attachment sought by another party (including the Licensor, Joint Owner(s) or Joint User(s)) and should be paid for any work it performs to accommodate such request. Where multiple parties join in a modification, each party's proportionate share of the total cost will be based on a ratio of the amount of new space occupied by that party to the total amount of new space occupied by all parties joining in the modification. Licensor shall not be required to use revenue that may result from the use of any additional space resulting from such replacement or rearrangement to compensate parties that paid for the modification.
- 7.1.8 Unless otherwise governed by law, all tree trimming made necessary, in the opinion of the Licensor, by reason of the Licensee's proposed attachments at the time of attachment provided the owner(s) of such trees grant permission to the Licensor, shall be performed by contractors approved by and under the direction of Licensor, at the sole expense of the Licensee.
- 7.1.9 Any such tree trimming that may be required on Licensee's customer's premises, to clear Licensee's cable drop, shall be performed by the Licensee at its expense.

7.1.10 Tree trimming needed as a result of adverse weather conditions such as wind, snow or ice storms, shall be performed by Licensor or its approved contractors. Since such tree trimming benefits Licensor, Licensee and other parties that may be lawfully attached to Licensor's poles, Licensee agrees to negotiate in good faith with the Licensor, on a case-by-case basis, to establish an appropriate sharing of costs associated with the tree trimming projects.

7.1.11 For each new facility attached by Licensee to Licensor's poles, on or after the date of execution of this Agreement, Licensee shall place identification tags on cables located on poles and identification apparatus tags on any associated items of Licensee's Facilities. Licensee shall also place these identification tags when engaged in an Overlash or Rebuild project. Overlashed bundles require one tag per bundle, per Licensee. The requirements for identification tags are set forth in the Blue Book.

7.1.12 When Licensor deems it an immediate threat to safety and/or an emergency exists, it may rearrange, transfer, or remove Licensee's attachments to Licensor's poles at Licensee's expense. Licensor shall make reasonable efforts to contact Licensee as circumstances permit.

7.2 Licensee's Routine Maintenance, Overlash, Rebuild Work and Placement of Power Supplies

7.2.1 Licensee shall work cooperatively with the local Verizon New England Reimbursable Construction Engineer when performing routine Maintenance Work on its facilities and/or attachments. Cooperative practices shall include a system of notification by phone, facsimile, answering system, or otherwise for scheduling purposes. Any work, which involves six or fewer adjacent spans shall be presumed to be routine Maintenance Work. Significant simultaneous maintenance activity within a geographic area may be deemed by Licensor to be Rebuild activity.

7.2.2 Licensee shall follow the procedures set forth in APPENDICES V, VI and VII, hereof, in performing Rebuild or Overlash work and placing power supplies.

ARTICLE VIII - INSPECTION OF LICENSEE'S FACILITIES

8.1 The Licensor reserves the right to make Post-construction, Subsequent, and Periodic Inspections of any part or all of Licensee's facilities attached to Licensor's poles and/or anchors. Licensor shall provide Licensee with a copy of any written report of such inspection within thirty (30) days following the inspection. Charges and billing for Inspections as set forth in Article III shall

apply, provided that Verizon New England commences Post-construction and Subsequent Inspections within 90 days after notification from Licensee that the work is complete.

- 8.2 Except as provided in Appendix VI and VII, Post-construction Inspections shall consist of a 10 percent sample of the poles to which the Licensee has attached facilities after completion of work. If Verizon New England determines that the Licensee is not in compliance at greater than 2 percent of the sampled locations, Verizon New England may inspect and bill Licensee to inspect all poles involved in the project. Within ten (10) days of the completion of a Post-construction Inspection, the Licensor shall notify the Licensee in writing of the date of completion of Post-construction inspection and its findings.
- 8.3 Where Post-construction Inspection by the Licensor has been completed and non-complying conditions have been identified, Licensee shall correct any non-complying conditions within thirty (30) days of the date of the written notice from the Licensor. If after said 30-day period Licensee has not corrected all such non-complying conditions, Licensor may notify Licensee that if all such non-complying conditions are not corrected within an additional 30-day period, no further attachment authorizations shall be issued to Licensee until Licensee's facilities are brought into compliance. If corrections are not made by Licensee within 30 days from the second notification by Licensor, the Licensor may perform or have performed such corrections and Licensee shall pay to the Licensor the cost of performing such work.
- 8.4 Licensor may undertake Subsequent Inspections to determine if appropriate corrective action has been taken by Licensee. If the Subsequent Inspection finds continued non-complying conditions, Licensor may perform or have performed corrective action at the sole expense of the Licensee or Licensor may terminate the license pursuant to Article X.
- 8.5 The making of Post-construction, Subsequent and/or Periodic Inspections or the failure to do so shall not operate to relieve Licensee of any responsibility, obligation, or liability specified in this Agreement.
- 8.6 Licensor reserves the right to make Periodic Inspections of all or any part of the attachments or facilities of Licensee at the expense of Licensee, upon sixty (60) days written notice to the Licensee. Periodic Inspections of the entire plant of the Licensee will not be made more often than once every five years unless, in Licensor's judgment, such inspections are required for reasons involving safety or because of an alleged violation by Licensee of the terms of this Agreement. Licensor shall make a reasonable effort to coordinate its Periodic Inspections with any Joint Owner.

ARTICLE IX - UNAUTHORIZED ATTACHMENTS

- 9.1 If any of Licensee's facilities are attached to Licensor's poles without being licensed, Licensor, may recover fees as specified in subpart 9.2, without prejudice to its other rights or remedies under this Agreement, including termination, or otherwise, and require Licensee to submit in writing, within thirty (30) days after receipt of written notification from Licensor of the unauthorized attachment, a pole attachment application. If such application is not received within the specified time period, Licensee shall remove its unauthorized attachments within thirty (30) days of the final date for submitting the required application, or Licensor may remove Licensee's attachments or facilities without liability at the Licensee's expense.
- 9.2 Upon discovery of an unauthorized attachment, Licensee agrees to pay an amount equal to five times the current applicable annual Attachment Fee specified in APPENDIX I times the number of unauthorized attachments. The penalty shall be in addition to all other amounts due and owing to Licensor under this Agreement.

ARTICLE X – TERMINATION

10.1 60-Day Termination

In addition to rights of termination provided to the Licensor under other provisions of this Agreement, the Licensor shall have the right to terminate Licensee's license, authorizations and/or rights granted under provisions of this Agreement where:

- (a) the Licensee's Facilities are maintained or used in violation of any law or in aid of an unlawful act or undertaking;
- (b) the Licensee ceases to have authority to construct and operate its facilities on public or private property at the location of the particular pole or anchor covered by the authorization;
- (c) the Licensee fails to comply with any of the terms and conditions of this Agreement or defaults in any of its obligations thereunder;
- (d) the Licensee attaches to a utility pole and/or anchor without having first been issued authorization therefor;
- (e) the Licensee, subject to provisions specified in Article II, ceases to provide its services;

- (f) the Licensee sublets or apports part of the licensed assigned space or otherwise permits its assigned space to be used by an entity or an affiliate not a party to this Agreement.

10.1.1 The Licenser will notify the Licensee in writing of any instances cited in this subpart. The Licensee shall take corrective action as necessary to eliminate the non-compliance and shall confirm in writing to the Licenser within sixty (60) days following such written notice that the non-compliance has ceased or been corrected. If Licensee fails to discontinue or correct non-compliance and fails to give the required written confirmation to the Licenser within the time stated above, the Licenser may terminate the license(s), authorization and/or rights granted hereunder for the poles and/or anchors at which such non-compliance has occurred.

10.2 Immediate Termination

Pole attachment license(s), authorization and/or rights are automatically and immediately terminated by the Licenser if:

- (a) except in circumstances in which Licenser has accepted evidence of self-insurance in accordance with Article XIV, the Licensee's insurance carrier shall at any time notify the Licenser that the policy or policies of insurance as required in Article XIV will be or have been cancelled or amended so that those requirements will no longer be satisfied;
- (b) the Licensee shall fail to pay any sum due under Article III or to deposit any sum required under this Agreement, or shall fail to maintain satisfactory surety as required in Article XII;
- (c) any authorization that may be required by any governmental or private authority for the construction, operation and maintenance of the Licensee's facilities on a pole or anchor is denied, revoked or cancelled.

10.3 General

10.3.1 In the event of termination of any of the Licensee's licenses, authorization and/or rights hereunder, the Licensee shall remove its facilities from the poles and anchors within sixty (60) days of the effective date of the termination; provided, however, that Licensee shall be liable for and pay all fees and charges pursuant to provisions of this Agreement to the Licenser until Licensee's facilities are actually removed from the utility pole(s) and anchor(s). If the Licensee fails to remove its facilities within

the specified period, the Licensor shall have the right to remove such facilities at the Licensee's expense and without liability on the part of the Licensor for damage or injury to such facilities or interruption of Licensee services.

10.3.2 When Licensee's facilities are removed from a pole or anchor, no attachment to the same pole or anchor shall be made until the Licensee has first complied with all of the provisions of this Agreement as though no such pole or anchor attachment had been made previously and all outstanding charges due to the Licensor for such pole or anchor have been paid in full.

10.3.3 Any license issued under this Agreement shall automatically terminate when Licensee ceases to have authority to construct, operate and/or maintain its attachments on the public or private property at the location of the particular pole covered by the license. Such automatic termination shall be stayed if the Licensee has sought judicial or regulatory review of the decision that: (1) has acted to terminate such authority or (2) has declared that the Licensee lacks such authority.

10.4 Licensee's Removal of Attachments

10.4.1 Licensee may at any time remove its attachments from a pole or anchor after first giving Licensor written notice of such removal. Licensee shall complete and provide to Licensor the Notification of Discontinuance of Use of Poles as contained in APPENDIX IV hereto. Licensor shall verify and execute such form within thirty (30) days of submission. Billing for the attachment shall cease as of the last day of the month in which verification occurs. Licensor may update this form from time to time during the term of this Agreement.

10.4.2 Following such removal, no attachment shall again be made to such pole until Licensee shall have complied first with all of the provisions of this Agreement as though no such attachment had been made previously.

ARTICLE XI - ASSIGNMENT OF RIGHTS

11.1 Licensee shall not assign or transfer this Agreement or any authorization granted hereunder, and this Agreement shall not inure to the benefit of Licensee's affiliates, successors or assigns without the prior written consent of Licensor, which consent shall not be unreasonably withheld; provided, however, no consent of Licensor is required if the Licensee assigns or transfers this Agreement to an affiliate and notifies the Licensor of such assignment or transfer, including any change in the notice address to be provided in accordance with subpart 15.3.

- 11.2 In the event such consent or consents are granted by Licensor, then this Agreement shall extend to and bind the affiliates, successors and assigns of the parties hereto.
- 11.3 Pole space licensed to Licensee hereunder is for the use of the Licensee named in this Agreement only, and Licensee shall not lease, sublicense, share with, convey or resell to any affiliates, subsidiaries, or any others any such space or rights granted hereunder.

ARTICLE XII - SURETY REQUIREMENTS

- 12.1 Upon request of Licensor, a new Licensee, or an existing Licensee that lacks a history of prompt payments shall furnish bond or other satisfactory evidence of financial security in an amount specified as follows in subpart 12.2 to guarantee the payment of any sums which may become due to the Licensor for Attachment Fees due hereunder and any other charges for work performed for Licensee by the Licensor, including the removal of Licensee's facility upon termination of any authorization issued hereunder.
- 12.2 Licensee shall furnish a bond or other security satisfactory to the Licensor in the following amounts: Security in the amount of \$20.00 shall be required for each authorized pole attachment. The total amount of security required hereunder shall not exceed \$300,000 or be less than \$1,000. Security will not be required where Licensee's total attachment authorizations do not exceed ten (10).
- 12.3 If the financial security is in the form of a bond or irrevocable Letter of Credit, such instrument shall be issued by a surety company or bank satisfactory to the Licensor. The instrument shall contain a provision that the surety company or bank will pay Licensor, within the dollar limits of the instrument, any sum demanded by the Licensor as due under the Agreement, whether or not the Licensee contests its liability to pay such sum, and whether or not the Licensor exercises or has exercised any option it may have to terminate. If any such amounts are paid by the surety company or bank, the Licensee shall restore the surety bond or Letter of Credit to the full amount required under this Article, within thirty (30) days after notice of such payment is sent to the Licensee.
- 12.4 The amount of the bond or the financial security shall not operate as a limitation upon the obligations of the Licensee.

ARTICLE XIII - LIABILITY AND DAMAGES

- 13.1 Licensor reserves to itself, its successors and assigns, the right to locate and maintain its poles and to operate its facilities in conjunction therewith in such a

manner as will best enable it to fulfill its own service requirements. Licensor shall not be liable to Licensee for any interruption of Licensee's service or for interference with the operation of Licensee's communications services arising in any manner, except from Licensor's sole negligence, out of the use of Licensor's poles.

- 13.2 Licensee shall exercise precaution to avoid damaging the facilities of Licensor and of others attached to Licensor's poles, and Licensee assumes all responsibility for any and all loss from such damage caused by Licensee's employees, agents or contractors. Licensee shall make an immediate report to Licensor and any other user of the occurrence of any such damage and agrees to reimburse the respective parties for all costs incurred in making repairs.
- 13.3 Licensor shall exercise precaution to avoid damaging the facilities of Licensee. Licensor shall make an immediate report to Licensee of the occurrence of any such damage and agrees to reimburse the respective parties for reasonable, direct costs incurred in making repairs.
- 13.4 Except to the extent as may be caused by the negligence of Licensor, Licensee shall defend, indemnify and save harmless Licensor against and from any and all liabilities, claims, suits, fines, penalties, damages, losses, fees, costs and expenses arising from or in connection with this Agreement (including reasonable attorneys' fees) including, but not limited to, those which may be imposed upon, incurred by or asserted against Licensor, by reason of:
- (a) any work or action done upon the poles licensed hereunder or any part thereof performed by Licensee or any of its agents, contractors, servants, or employees;
 - (b) any use, occupation, condition, operation of said poles or any part thereof by Licensee or any of its agents, contractors, servants, or employees;
 - (c) any act or omission on the part of Licensee or any of its agents, contractors, servants, or employees, for which Licensor may be found liable;
 - (d) any accident, injury (including death) or damage to any person or property occurring upon said poles or any part thereof arising out of any use thereof by Licensee or any of its agents, contractors, servants, or employees;
 - (e) any failure on the part of Licensee to perform or comply with any of the covenants, agreements, terms or conditions contained in this Agreement;

- (f) payments made under any Workers' Compensation Law or under any plan for employees disability and death benefits arising out of any use of the poles by Licensee or any of its agents, contractors, servants, or employees;
- (g) the erection, maintenance, presence, use, occupancy or removal of Licensee's Facilities by Licensee or any of its agents, contractors, servants, or employees or by their proximity to the facilities of other parties attached to Licensor's poles; provided that Licensee shall defend, indemnify, and save harmless Licensor against and from any and all such liabilities, claims, suits, fines, penalties, damages, losses, fees, costs and expenses brought, made or asserted by any of Licensee's agents, contractors, servants, or employees of any of Licensee's contractors or agents; or by
- (h) any and all such liabilities, claims, suits, fines, penalties, damages, losses, fees, costs and expenses brought, made or asserted by any of Licensee's agents, contractors, servants, or employees of any of Licensee's contractors or agents.

13.5 Licensee shall indemnify, save harmless and defend Licensor from any and all claims and demands of whatever kind which arise directly or indirectly from the operation of Licensee's attachments, including taxes, special charges by others, claims and demands for damages or loss for infringement of copyright, for libel and slander, for unauthorized use of television broadcast programs, and for unauthorized use of other program material, and from and against all claims and demands for infringement of patents with respect to the manufacture, use and operation of Licensee's poles, or otherwise.

The provisions of this Article shall survive the expiration or earlier termination of this Agreement or any license issued thereunder.

ARTICLE XIV - INSURANCE

14.1 Licensee and its subcontractors (if any) agree to purchase and maintain during the term hereof all insurance and/or bonds required by law or this Agreement including without limitation:

- (a) Commercial General Liability Insurance (including, but not limited to, premises-operations, explosion and collapse, underground hazard, broad form property damage, products/completed operations, contractual liability, independent contractors, personal injury) with limits of at least \$2,000,000. combined single limit for each occurrence. (Limits may be satisfied with primary and/or excess coverage.)

- (b) Commercial Automobile Liability with limits of at least \$2,000,000. combined single limit for each occurrence.

If the Licensee does not own or operate any vehicles/automobiles associated with the Licensee's business, and will not be operating any vehicles/automobiles to place, maintain or remove cables, equipment or facilities on poles covered by this Agreement, but instead, uses now and/or in the future a contractor to place, maintain or remove cables, equipment or facilities on poles covered by this agreement, then the Licensee must provide satisfactory evidence that its subcontractor has purchased and maintained during the term hereof Commercial Automobile Liability Insurance of at least \$2,000,000. combined single limit for each occurrence.

- (c) Workers' Compensation insurance as required by Statute, and Employer's Liability insurance with limits of not less than \$1,000,000. per occurrence.

- 14.2 Licensee shall waive its right of subrogation against Licensor for Workers' Compensation claims.
- 14.3 All insurance must be in effect before Licensor will authorize Licensee to make attachment to Licensor's pole(s) and shall remain in force until such Attachments have been removed from all such poles.
- 14.4 Licensee shall annually submit to Licensor satisfactory evidence of such insurance by an ACORD Form or other satisfactory form in general use by the insurance industry for each company insuring Licensee to the effect that it has insured Licensee for all liabilities of Licensee covered by this Agreement; and that such certificates will provide evidence of waiver of subrogation, name the Licensor as an additional insured under the General Liability and Auto Liability policies and that it will not cancel or change any such policy of insurance issued to Licensee except after giving not less than thirty (30) days written notice to Licensor. In the case of a self-insured Licensee, Licensor may elect to accept satisfactory evidence of such self-insurance in lieu of the ACORD Form.
- 14.5 The above limits of insurance may be satisfied by a combination of primary and excess insurance policies.

ARTICLE XV - GENERAL PROVISIONS

15.1 Authorization Not Exclusive

Nothing herein contained shall be construed as a grant of any exclusive authorization, right or privilege to Licensee. Licensor shall have the right to

grant, renew and extend rights and privileges to others not parties to this Agreement, by contract or otherwise, to use any pole covered by this Agreement.

15.2 Failure to Enforce

Failure of Licensor to enforce or insist upon compliance with any of the terms or conditions of this Agreement or to give notice or declare this Agreement or any authorization granted hereunder terminated shall not constitute a general waiver or relinquishment of any term or condition of this Agreement, but the same shall be and remain at all times in full force and effect.

15.3 Notices

APPENDIX II sets forth where written notices required under this agreement shall be sent to Licensor and Licensee. Notice shall be acceptable in the following forms: first class mail, or if time-sensitive, facsimile followed by first class mail or overnight mail with receipt. Licensee shall complete APPENDIX II and submit it to Licensor with this Agreement.

15.4 Severability

If any of the provisions of this Agreement shall be invalid or unenforceable, such invalidity or unenforceability shall not invalidate or render unenforceable the entire Agreement, but rather the entire Agreement shall be construed as if not containing the particular invalid or unenforceable provision or provisions. If the invalid or unenforceable provision or provisions shall be considered an essential element of this Agreement, the parties shall promptly attempt to negotiate a substitute therefor.

15.5 Choice of Law

The construction, interpretation and performance of this Agreement shall be governed by and construed in accordance with the laws of the State or Commonwealth where the Licensor's poles are located, as set forth in this Agreement, without regard to the principles of conflicts of law. All actions under this Agreement shall be brought in a court of competent subject-matter jurisdiction of the county of the capital of such State or Commonwealth or a regulatory agency with subject-matter jurisdiction, and both parties agree to accept and submit to the personal jurisdiction of such court or regulatory agency. Licensee also agrees to submit to the jurisdiction of any court in the United States wherein an action is commenced against Licensor based on a claim for which Licensee has indemnified Licensor hereunder.

15.6 Compliance with Laws

The parties hereto shall at all times observe and comply with, and the provisions of this Agreement are subject to, all laws, ordinances, and regulations which in any manner affect the rights and obligations of the parties hereto under this Agreement, so long as such laws, ordinances, or regulations remain in effect.

Licensee agrees to indemnify and hold harmless Licensor for, from and against and defend Licensor against, any loss or damage sustained because of Licensee's noncompliance hereunder.

15.7 Survival

All rights and obligations hereunder granted or incurred prior to and which by their nature would continue beyond the cancellation, termination, or expiration of this Agreement shall survive such cancellation, termination, or expiration.

15.8 Use of Information

Licensee may provide to Licensor license applications and business plans of its future needs for pole attachments. Such information will allow Licensor to better forecast personnel and equipment requirements. However, as to business plans, such information shall be deemed for use as advance planning purposes only, and no obligation shall be created that Licensor hire personnel or purchase equipment, or Licensee submit license applications for the pole attachments. Such information shall be used only by such employees or contractors of Licensor who have responsibilities relating to the administration of, or to work to be performed under, this Agreement and said employees shall treat such information as Licensor treats its own confidential information of similar type and value. Licensor's obligations hereunder shall not extend to any information that are now available to the public or become available by reason of acts or omissions not attributable to Licensor.

15.9 Access to Records

Licensor, upon receipt of written request, shall provide access to Licensor's pole records in accordance with "Job Aid For Requests To Records" attached hereto as APPENDIX VIII. Licensor may update this form from time to time during the term of this Agreement.

15.10 Dispute Resolution

In the case where Licensee claims that a term or condition is unjust or unreasonable, Licensee shall submit a complaint to the Manager-License

Administration Group, specifying all information and its argument relied on to justify its claim. Licensor shall provide a written response to such complaint within 10 business days after receipt of the complaint. Such response shall specifically address all contentions made by Licensee. If Licensee continues to have issues, it may request a meeting with Manager-License Administration Group to discuss such issues. Such meeting shall be held within five (5) business days. If the Licensee is not satisfied with the results of such meeting, it may file a complaint with the regulatory body of competent jurisdiction.

15.11 Emergency Conditions

All parties shall work cooperatively in the case of an emergency to restore service to their respective customers.

ARTICLE XVI - TERM OF AGREEMENT

Except as provided below, this Agreement shall remain in effect; provided, however, that the Licensor may, not less than two years from this date and upon written notice, require the Licensee to engage in good-faith negotiations with the Licensor to amend the Agreement to comport with regulatory changes or obligations. If the parties cannot agree to an amendment, they shall submit the matter to the regulatory agency with jurisdiction to resolve the matter. The Agreement may be terminated by Licensee by written notice of termination no less than 30 days prior to the effective date of such termination; provided, however, that such early termination shall not become effective until the Licensee has discontinued all existing licenses and has removed any and all facilities. The Agreement may be terminated upon written notice by the Licensor if, within one year from the date of this Agreement, the Licensee has placed no facilities on the Licensor's poles in accordance with the Agreement.

Upon execution, this Agreement cancels and supersedes all previously executed Agreements between the parties with respect to the subject matter contained herein.

IN WITNESS WHEREOF, the parties hereto have executed this Agreement in multiple originals on the day and year first above written.

VERIZON NEW ENGLAND INC.

By: S. Mercer

(Print Name) S. Mercer

(Title) for Director ASP E+P

(Date) 4/9/04

Licensor PUBLIC SERVICE COMPANY OF NEW HAMPSHIRE

By: J. G. Libby

(Print Name) John G. Libby

(Title) Director of Energy Delivery

(Date) 3/29/04

Licensee FREEDOM RING COMMUNICATIONS, LLC. d/b/a Bayring Communications

By: Steve Wengert

(Print Name) Steve Wengert

(Title) Director of Operations

(Date) 4/7/04

APPENDICES

- I. ATTACHMENT FEES and CHARGES
- II. NOTICE ADDRESSES
- III. PLANNING MANAGER'S AREA
- IV. LICENSE APPLICATIONS FORMS
 - Application and Pole Attachment License Form 1
 - Authorization for Field Survey Work Form 2
 - Itemized Pole Make-ready Work and Charges Form 3
 - Authorization for Pole Make-ready Work Form 4
 - Licensee Itemized Self Survey Form 5
 - Notification of Discontinuance of Use of Poles Form 6
 - Project Management Request Form 7
 - Licensee to RCE Notification Form 8
 - Power Supply Schematic Form 10
- V. REBUILD
- VI. OVERLASH BY LICENSEE TO THEIR OWN FACILITIES
- VII. POWER SUPPLIES
- VIII. JOB AID FOR REQUESTS TO RECORDS

APPENDIX I

ATTACHMENT FEES and CHARGES VERIZON NEW ENGLAND Inc.

1. Attachment Fees

Annual Attachment Fees are as follow:

State	JO/JU	Sole Owned
MA	\$2.40	\$4.80
ME	\$4.80	\$9.60
NH	\$4.84	\$9.67
RI	\$3.32	\$6.64

VT ATTACHMENT FEES and CHARGES Effective January 01, 2002

- \$3.44** Cable Television Operators (not providing local exchange telephone service) - per attachment, per Verizon-VT jointly owned or used pole, per year.
- \$6.87** Cable Television Operators (not providing local exchange telephone service) – per attachment, per Verizon VT solely owned pole, per year.
- \$13.74** Other Attaching Entities (excluding Cable Television Operators not providing local telephone service) – per attachment, per Verizon VT solely owned pole, per year.
- \$ 6.87** Other Attaching Entities (excluding Cable Television Operators not providing local exchange telephone service) – per attachment, per Verizon-VT jointly owned or used pole, per year.

For poles in Burlington Electric Department service territory only:

- \$3.09** Cable Television Operators (not providing local exchange telephone service) - per attachment, per Verizon VT jointly owned or used pole, per year.

\$6.18 Other Attaching Entities (excluding Cable Television Operators not providing local exchange telephone service) – per attachment, per Verizon VT jointly owned pole, per year.

Attachment Fees are calculated from the first day of the month following the date the license is issued.

Fees shall be payable annually in advance, unless otherwise provided. Payment is due within the later of thirty (30) days from the first day of January or thirty (30) days from the date the bill is issued.

**PUBLIC SERVICE OF NEW HAMPSHIRE
 POLE ATTACHMENT AGREEMENT**

**2012 CATV AND TELECOMMUNICATIONS COMPANY ATTACHMENT FEES
 AND PRE-CONSTRUCTION FIELD SURVEY CHARGES**

1. Attachment Fees:

Cable TV & Cable TV and Cable Modem Internet Service	
\$10.07	Solely owned poles
\$5.04	Jointly owned poles
\$3.36	Tri owned poles
Telecommunication services (including cable TV operators providing telecommunication services)	
\$22.96	Non-urbanized solely owned poles
\$11.48	Non-urbanized jointly owned poles
\$7.65	Non-urbanized tri owned poles
\$15.22	Urbanized solely owned poles
\$7.61	Urbanized jointly owned poles
\$5.07	Urbanized tri owned poles

Attachment fees provided by NU – Pricing Strategy & Administration Department

Attachment fees are calculated from the first day of the month following the date the license is issued.

Fees shall be payable semi-annually in advance, unless otherwise provided. Payment is due within the later of thirty (30) days from the first day of January and the first day of July or thirty (30) days from the date the bill is issued.

2. Pre-construction Field Survey Charges:

ROADSIDE FIELD SURVEY CHARGES

\$294.00 + \$5.38 per pole, for all number of poles

Roadside field survey charges are subject to change based on a periodic review of actual costs to perform pre-construction surveys.

RIGHT OF WAY FIELD SURVEY CHARGES

Right-of-Way field survey charges will be estimated on a case by case basis after review by PSNH Civil Engineering.

UNIT PRICES FOR MAKE READY WORK – VERIZON (VZ) -MASS - NO

12/10/1999

TASK #	TASK DESCRIPTION	ACCT CODE	TOTAL COST
1A	PLACE 40 FT POLE - 100% VZ OWNED	1C	\$735.90
1B	PLACE 40 FT POLE - 50% VZ OWNED	1C	\$367.95
2A	PLACE 45 FT POLE - 100% VZ OWNED	1C	\$821.70
2B	PLACE 45 FT POLE - 50% VZ OWNED	1C	\$410.85
3A	PLACE OTHER SIZE POLE _____ - 100% VZ OWNED	1C	\$ -
3B	PLACE OTHER SIZE POLE _____ - 50% VZ OWNED	1C	\$ -
4	REMOVE POLE - ALL SIZES - INCLUDING DISPOSAL	1X	\$423.50
5	DEPRECIATION CREDIT	1X	
6	PLACE ANCHOR - ALL TYPES/SIZES	1C	\$425.70
7A	PLACE PA OR PP GUY	1C	\$145.20
7B	PLACE EACH ADDITIONAL PA OR PP GUY (same pole)	1C	\$69.30
8A	PLACE NEW DROP WIRE	42C	\$107.80
8B	PLACE NEW 50 PR TERMINAL	122C	\$243.10
9A	TRANSFER GUY ATTACHMENT	1M	\$135.30
9B	TRANSFER ADDITIONAL GUY ATTACHMENTS (same pole)	1M	\$63.80
10A	MOVE/RAISE/LOWER GUY ATTACHMENT	1M	\$135.30
10B	MOVE/RAISE/LOWER ADD'L GUY ATTACHMENT (same pole)	1M	\$63.80
11A	TRANSFER/MOVE/RAISE/LOWER CABLE (one strand)	2M	\$152.90
11B	TRANSFER/MOVE/RAISE/LOWER ADDITIONAL CABLES (per strand)	2M	\$50.60
12	TRANSFER POLE DIP	2M	\$342.10
13	TRANSFER CROSS-CONNECT CABINET	2M	\$358.60
14A	TRANSFER/MOVE DISTRIBUTION TERMINAL	2M	\$149.60
14B	TRANSFER/MOVE ADDITIONAL DISTRIBUTION TERMINALS (same pole)	2M	\$47.30
15	TRANSFER APPARATUS CASE OR SLACK BOX	2M	\$220.00
16A	TRANSFER LICENSEE CABLE ATTACHMENT	1M	\$124.30
16B	TRANSFER EACH ADD'L LICENSEE CABLE ATT (strands) (same pole)	1M	\$51.70
17A	TRANSFER DROP WIRE	42M	\$92.40
17B	TRANSFER EACH ADDITIONAL DROP WIRE (same pole)	42M	\$22.00
18A	TRANSFER C RURAL WIRE	3M	\$92.40
18B	TRANSFER EACH ADDITIONAL C RURAL WIRE (same pole)	3M	\$22.00
19A	MOVE/RAISE/LOWER DROP WIRE	42M	\$92.40
19B	MOVE/RAISE/LOWER EACH ADDITIONAL DROP WIRE (same pole)	42m	\$22.00
20A	MOVE/RAISE/LOWER C RURAL WIRE	3M	\$92.40
20B	MOVE/RAISE/LOWER EACH ADDITIONAL C RURAL WIRE (same pole)	3M	\$22.00
21A	TRANSFER WIRE TERMINAL	2M	\$91.30
21B	TRANSFER EACH ADDITIONAL WIRE TERMINAL (same pole)	2M	\$17.60
22A	REPLACE ONE DROP WIRE	42M	\$127.60
22B	REPLACE ADDITIONAL DROP WIRES (same pole)	42M	\$56.10
23A	TRANSFER LICENSEE DROP WIRE	42M	\$92.40
23B	TRANSFER EACH ADDITIONAL LICENSEE DROP WIRE (same pole)	42M	\$22.00
24A	REMOVE ANCHOR - ALL SIZES	1X	\$106.70
24B	REMOVE EACH ADDITIONAL ANCHOR (same pole)	1X	\$31.90
25A	REMOVE PA OR PP GUY	1X	\$135.30
25B	REMOVE EACH ADDITIONAL PA OR PP GUY (same pole)	1X	\$60.50
26	SITE PROTECTION (POLICE/TRAFFIC CONTROL)		\$ -
27	ROOM & BOARD		\$ -
28	TREE TRIMMING		\$ -
29	CUT AND KICK POLE - ALL SIZES - IN ADDITION TO POLE PLACEMENT AND REMOVAL	1C	\$184.80
30	OTHER MAKE READY WORK REQUIRED (LIST)		\$ -
	TOTAL MAKE READY WORK CHARGES		

UNIT PRICES FOR SURVEYS AND INSPECTIONS-VERIZON-MASS-NO

12/10/1999

TASK #	TASK DESCRIPTION	ACCT CODE	TOTAL COST
1	PRECONSTRUCTION SURVEYS (PER APPLICATION)		
	1-10 POLES (including travel time for first day)	2M	\$275.00
	11-200 POLES	2M	\$9.90/pole
	TRAVEL TIME (FOR SECOND AND SUBSEQUENT DAYS)(SAME APP) (Based on 75 poles surveyed per day)	2M	\$200/DAY
2	POST-CONSTRUCTION INSPECTION (PER APPLICATION)		
	1-10 POLES (including travel time for first day)	2M	\$275.00
	11-200 POLES	2M	\$8.25/pole
	TRAVEL TIME (FOR SECOND AND SUBSEQUENT DAYS)(SAME APP) (Based on 100 poles surveyed per day)	2M	\$200/DAY
3	SUBSEQUENT INSPECTION (PER APPLICATION)		
	1-10 POLES (including travel time for first day)	2M	\$275.00
	11-200 POLES	2M	\$4.95/pole
	TRAVEL TIME (FOR SECOND AND SUBSEQUENT DAYS)(SAME APP) (Based on 150 poles surveyed per day)	2M	\$200/DAY
4	PERIODIC POLE SURVEYS		
	BASED ON GEOGRAPHIC AREA AND NEGOTIATED UNIT PRICE PER POLE	1M	Not to exceed \$6 PER POLE

UNIT PRICES FOR MAKE READY WORK - VERIZON (VZ) -MASS - NE

12/10/1999

TASK #	TASK DESCRIPTION	ACCT CODE	TOTAL COST
1A	PLACE 40 FT POLE - 100% VZ OWNED	1C	\$731.50
1B	PLACE 40 FT POLE - 50% VZ OWNED	1C	\$365.75
2A	PLACE 45 FT POLE - 100% VZ OWNED	1C	\$862.40
2B	PLACE 45 FT POLE - 50% VZ OWNED	1C	\$431.20
3A	PLACE OTHER SIZE POLE _____ - 100% VZ OWNED	1C	
3B	PLACE OTHER SIZE POLE _____ - 50% VZ OWNED	1C	
4	REMOVE POLE - ALL SIZES - INCLUDING DISPOSAL	1X	\$423.50
5	DEPRECIATION CREDIT	1X	
6	PLACE ANCHOR - ALL TYPES/SIZES	1C	\$342.10
7A	PLACE PA OR PP GUY	1C	\$149.60
7B	PLACE EACH ADDITIONAL PA OR PP GUY (same pole)	1C	\$85.80
8A	PLACE NEW DROP WIRE	42C	\$115.50
8B	PLACE NEW 50 PR TERMINAL	122C	\$246.40
9A	TRANSFER GUY ATTACHMENT	1M	\$184.80
9B	TRANSFER ADDITIONAL GUY ATTACHMENTS (same pole)	1M	\$85.80
10A	MOVE/RAISE/LOWER GUY ATTACHMENT	1M	\$184.80
10B	MOVE/RAISE/LOWER ADD'L GUY ATTACHMENT (same pole)	1M	\$85.80
11A	TRANSFER/MOVE/RAISE/LOWER CABLE (one strand)	2M	\$165.00
11B	TRANSFER/MOVE/RAISE/LOWER ADDITIONAL CABLES (per strand)	2M	\$53.90
12	TRANSFER POLE DIP	2M	\$390.50
13	TRANSFER CROSS-CONNECT CABINET	2M	\$385.00
14A	TRANSFER/MOVE DISTRIBUTION TERMINAL	2M	\$160.60
14B	TRANSFER/MOVE ADDITIONAL DISTRIBUTION TERMINALS (same pole)	2M	\$51.70
15	TRANSFER APPARATUS CASE OR SLACK BOX	2M	\$236.50
16A	TRANSFER LICENSEE CABLE ATTACHMENT	1M	\$168.30
16B	TRANSFER EACH ADD'L LICENSEE CABLE ATT (strands) (same pole)	1M	\$70.40
17A	TRANSFER DROP WIRE	42M	\$100.10
17B	TRANSFER EACH ADDITIONAL DROP WIRE (same pole)	42M	\$23.10
18A	TRANSFER C RURAL WIRE	3M	\$99.00
18B	TRANSFER EACH ADDITIONAL C RURAL WIRE (same pole)	3M	\$23.10
19A	MOVE/RAISE/LOWER DROP WIRE	42M	\$100.10
19B	MOVE/RAISE/LOWER EACH ADDITIONAL DROP WIRE (same pole)	42m	\$23.10
20A	MOVE/RAISE/LOWER C RURAL WIRE	3M	\$99.00
20B	MOVE/RAISE/LOWER EACH ADDITIONAL C RURAL WIRE (same pole)	3M	\$23.10
21A	TRANSFER WIRE TERMINAL	2M	\$97.90
21B	TRANSFER EACH ADDITIONAL WIRE TERMINAL (same pole)	2M	\$19.80
22A	REPLACE ONE DROP WIRE	42M	\$137.50
22B	REPLACE ADDITIONAL DROP WIRES (same pole)	42M	\$61.60
23A	TRANSFER LICENSEE DROP WIRE	42M	\$100.10
23B	TRANSFER EACH ADDITIONAL LICENSEE DROP WIRE (same pole)	42M	\$23.10
24A	REMOVE ANCHOR - ALL SIZES	1X	\$106.70
24B	REMOVE EACH ADDITIONAL ANCHOR (same pole)	1X	\$31.90
25A	REMOVE PA OR PP GUY	1X	\$135.39
25B	REMOVE EACH ADDITIONAL PA OR PP GUY (same pole)	1X	\$60.50
26	SITE PROTECTION (POLICE/TRAFFIC CONTROL)		\$
27	ROOM & BOARD		\$
28	TREE TRIMMING		\$
29	CUT AND KICK POLE - ALL SIZES - IN ADDITION TO POLE PLACEMENT AND REMOVAL	1C	\$191.40
30	OTHER MAKE READY WORK REQUIRED (LIST)		\$
	TOTAL MAKE READY WORK CHARGES		

UNIT PRICES FOR SURVEYS AND INSPECTIONS-VERIZON-MASS-NE

12/10/1999

TASK #	TASK DESCRIPTION	ACCT CODE	TOTAL COST
1	PRECONSTRUCTION SURVEYS (PER APPLICATION)		
	1-10 POLES	2M	\$275.00
	11-200 POLES	2M	\$9.90/pole
	TRAVEL TIME (FOR SECOND AND SUBSEQUENT DAYS)(SAME APP) (Based on 75 poles surveyed per day)	2M	\$200/DAY
2	POST-CONSTRUCTION INSPECTION (PER APPLICATION)		
	1-10 POLES	2M	\$275.00
	11-200 POLES	2M	\$8.25/pole
	TRAVEL TIME (FOR SECOND AND SUBSEQUENT DAYS)(SAME APP) (Based on 100 poles surveyed per day)	2M	\$200/DAY
3	SUBSEQUENT INSPECTION (PER APPLICATION)		
	1-10 POLES	2M	\$275.00
	11-200 POLES	2M	\$4.95/pole
	TRAVEL TIME (FOR SECOND AND SUBSEQUENT DAYS)(SAME APP) (Based on 150 poles surveyed per day)	2M	\$200/DAY
4	PERIODIC POLE SURVEYS		
	BASED ON GEOGRAPHIC AREA AND NEGOTIATED UNIT PRICE PER POLE	1M	Not to exceed \$6 PER POLE

UNIT PRICES FOR MAKE READY WORK - VERIZON (VZ) -MASS - SO

12/10/1999

TASK #	TASK DESCRIPTION	ACCT CODE	TOTAL COST
1A	PLACE 40 FT POLE - 100% VZ OWNED	1C	\$732.60
1B	PLACE 40 FT POLE - 50% VZ OWNED	1C	\$366.30
2A	PLACE 45 FT POLE - 100% VZ OWNED	1C	\$811.80
2B	PLACE 45 FT POLE - 50% VZ OWNED	1C	\$405.90
3A	PLACE OTHER SIZE POLE _____ - 100% VZ OWNED	1C	\$ -
3B	PLACE OTHER SIZE POLE _____ - 50% VZ OWNED	1C	\$ -
4	REMOVE POLE - ALL SIZES - INCLUDING DISPOSAL	1X	\$400.40
5	DEPRECIATION CREDIT	1X	
6	PLACE ANCHOR - ALL TYPES/SIZES	1C	\$326.70
7A	PLACE PA OR PP GUY	1C	\$147.40
7B	PLACE EACH ADDITIONAL PA OR PP GUY (same pole)	1C	\$70.40
8A	PLACE NEW DROP WIRE	42C	\$104.50
8B	PLACE NEW 50 PR TERMINAL	122C	\$224.40
9A	TRANSFER GUY ATTACHMENT	1M	\$135.30
9B	TRANSFER ADDITIONAL GUY ATTACHMENTS (same pole)	1M	\$62.70
10A	MOVE/RAISE/LOWER GUY ATTACHMENT	1M	\$135.30
10B	MOVE/RAISE/LOWER ADD'L GUY ATTACHMENT (same pole)	1M	\$62.70
11A	TRANSFER/MOVE/RAISE/LOWER CABLE (one strand)	2M	\$149.60
11B	TRANSFER/MOVE/RAISE/LOWER ADDITIONAL CABLES (per strand)	2M	\$48.40
12	TRANSFER POLE DIP	2M	\$332.20
13	TRANSFER CROSS-CONNECT CABINET	2M	\$349.80
14A	TRANSFER/MOVE DISTRIBUTION TERMINAL	2M	\$145.20
14B	TRANSFER/MOVE ADDITIONAL DISTRIBUTION TERMINALS (same pole)	2M	\$46.20
15	TRANSFER APPARATUS CASE OR SLACK BOX	2M	\$213.40
16A	TRANSFER LICENSEE CABLE ATTACHMENT	1M	\$123.20
16B	TRANSFER EACH ADD'L LICENSEE CABLE ATT (strands) (same pole)	1M	\$52.80
17A	TRANSFER DROP WIRE	42M	\$90.20
17B	TRANSFER EACH ADDITIONAL DROP WIRE (same pole)	42M	\$20.90
18A	TRANSFER C RURAL WIRE	3M	\$91.30
18B	TRANSFER EACH ADDITIONAL C RURAL WIRE (same pole)	3M	\$20.90
19A	MOVE/RAISE/LOWER DROP WIRE	42M	\$90.20
19B	MOVE/RAISE/LOWER EACH ADDITIONAL DROP WIRE (same pole)	42m	\$20.90
20A	MOVE/RAISE/LOWER C RURAL WIRE	3M	\$91.30
20B	MOVE/RAISE/LOWER EACH ADDITIONAL C RURAL WIRE (same pole)	3M	\$20.90
21A	TRANSFER WIRE TERMINAL	2M	\$88.00
21B	TRANSFER EACH ADDITIONAL WIRE TERMINAL (same pole)	2M	\$18.70
22A	REPLACE ONE DROP WIRE	42M	\$124.30
22B	REPLACE ADDITIONAL DROP WIRES (same pole)	42M	\$55.00
23A	TRANSFER LICENSEE DROP WIRE	42M	\$90.20
23B	TRANSFER EACH ADDITIONAL LICENSEE DROP WIRE (same pole)	42M	\$20.90
24A	REMOVE ANCHOR - ALL SIZES	1X	\$101.20
24B	REMOVE EACH ADDITIONAL ANCHOR (same pole)	1X	\$24.20
25A	REMOVE PA OR PP GUY	1X	\$127.60
25B	REMOVE EACH ADDITIONAL PA OR PP GUY (same pole)	1X	\$63.80
26	SITE PROTECTION (POLICE/TRAFFIC CONTROL)		\$ -
27	ROOM & BOARD		\$ -
28	TREE TRIMMING		\$ -
29	CUT AND KICK POLE - ALL SIZES - IN ADDITION TO POLE PLACEMENT AND REMOVAL	1C	\$189.20
30	OTHER MAKE READY WORK REQUIRED (LIST)		\$ -
	TOTAL MAKE READY WORK CHARGES		

UNIT PRICES FOR SURVEYS AND INSPECTIONS-VERIZON-MASS-SO

12/10/1999

TASK #	TASK DESCRIPTION	ACCT CODE	TOTAL COST
1	PRECONSTRUCTION SURVEYS (PER APPLICATION)		
	1-10 POLES (including travel time for first day)	2M	\$275.00
	11-200 POLES	2M	\$9.90/pole
	TRAVEL TIME (FOR SECOND AND SUBSEQUENT DAYS)(SAME APP) (Based on 75 poles surveyed per day)	2M	\$200/DAY
2	POST-CONSTRUCTION INSPECTION (PER APPLICATION)		
	1-10 POLES (including travel time for first day)	2M	\$275.00
	11-200 POLES	2M	\$8.25/pole
	TRAVEL TIME (FOR SECOND AND SUBSEQUENT DAYS)(SAME APP) (Based on 100 poles surveyed per day)	2M	\$200/DAY
3	SUBSEQUENT INSPECTION (PER APPLICATION)		
	1-10 POLES (including travel time for first day)	2M	\$275.00
	11-200 POLES	2M	\$4.95/pole
	TRAVEL TIME (FOR SECOND AND SUBSEQUENT DAYS)(SAME APP) (Based on 150 poles surveyed per day)	2M	\$200/DAY
4	PERIODIC POLE SURVEYS		
	BASED ON GEOGRAPHIC AREA AND NEGOTIATED UNIT PRICE PER POLE	1M	Not to exceed \$6 PER POLE

UNIT PRICES FOR MAKE READY WORK - VERIZON (VZ) -MASS - SE

12/10/1999

TASK #	TASK DESCRIPTION	ACCT CODE	TOTAL COST
1A	PLACE 40 FT POLE - 100% VZ OWNED	1C	\$790.90
1B	PLACE 40 FT POLE - 50% VZ OWNED	1C	\$395.45
2A	PLACE 45 FT POLE - 100% VZ OWNED	1C	\$866.80
2B	PLACE 45 FT POLE - 50% VZ OWNED	1C	\$433.40
3A	PLACE OTHER SIZE POLE _____ - 100% VZ OWNED	1C	\$ -
3B	PLACE OTHER SIZE POLE _____ - 50% VZ OWNED	1C	\$ -
4	REMOVE POLE - ALL SIZES - INCLUDING DISPOSAL	1X	\$519.20
5	DEPRECIATION CREDIT	1X	
6	PLACE ANCHOR - ALL TYPES/SIZES	1C	\$420.20
7A	PLACE PA OR PP GUY	1C	\$178.20
7B	PLACE EACH ADDITIONAL PA OR PP GUY (same pole)	1C	\$85.80
8A	PLACE NEW DROP WIRE	42C	\$146.30
8B	PLACE NEW 50 PR TERMINAL	122C	\$302.50
9A	TRANSFER GUY ATTACHMENT	1M	\$190.30
9B	TRANSFER ADDITIONAL GUY ATTACHMENTS (same pole)	1M	\$89.10
10A	MOVE/RAISE/LOWER GUY ATTACHMENT	1M	\$190.30
10B	MOVE/RAISE/LOWER ADD'L GUY ATTACHMENT (same pole)	1M	\$89.10
11A	TRANSFER/MOVE/RAISE/LOWER CABLE (one strand)	2M	\$210.10
11B	TRANSFER/MOVE/RAISE/LOWER ADDITIONAL CABLES (per strand)	2M	\$69.30
12	TRANSFER POLE DIP	2M	\$469.70
13	TRANSFER CROSS-CONNECT CABINET	2M	\$536.80
14A	TRANSFER/MOVE DISTRIBUTION TERMINAL	2M	\$205.70
14B	TRANSFER/MOVE ADDITIONAL DISTRIBUTION TERMINALS (same pole)	2M	\$64.90
15	TRANSFER APPARATUS CASE OR SLACK BOX	2M	\$302.50
16A	TRANSFER LICENSEE CABLE ATTACHMENT	1M	\$174.90
16B	TRANSFER EACH ADD'L LICENSEE CABLE ATT (strands) (same pole)	1M	\$72.60
17A	TRANSFER DROP WIRE	42M	\$126.50
17B	TRANSFER EACH ADDITIONAL DROP WIRE (same pole)	42M	\$29.70
18A	TRANSFER C RURAL WIRE	3M	\$122.10
18B	TRANSFER EACH ADDITIONAL C RURAL WIRE (same pole)	3M	\$27.50
19A	MOVE/RAISE/LOWER DROP WIRE	42M	\$126.50
19B	MOVE/RAISE/LOWER EACH ADDITIONAL DROP WIRE (same pole)	42m	\$29.70
20A	MOVE/RAISE/LOWER C RURAL WIRE	3M	\$122.10
20B	MOVE/RAISE/LOWER EACH ADDITIONAL C RURAL WIRE (same pole)	3M	\$27.50
21A	TRANSFER WIRE TERMINAL	2M	\$124.30
21B	TRANSFER EACH ADDITIONAL WIRE TERMINAL (same pole)	2M	\$26.40
22A	REPLACE ONE DROP WIRE	42M	\$173.80
22B	REPLACE ADDITIONAL DROP WIRES (same pole)	42M	\$77.00
23A	TRANSFER LICENSEE DROP WIRE	42M	\$126.50
23B	TRANSFER EACH ADDITIONAL LICENSEE DROP WIRE (same pole)	42M	\$29.70
24A	REMOVE ANCHOR - ALL SIZES	1X	\$130.90
24B	REMOVE EACH ADDITIONAL ANCHOR (same pole)	1X	\$39.60
25A	REMOVE PA OR PP GUY	1X	\$166.10
25B	REMOVE EACH ADDITIONAL PA OR PP GUY (same pole)	1X	\$73.70
26	SITE PROTECTION (POLICE/TRAFFIC CONTROL)		\$ -
27	ROOM & BOARD		\$ -
28	TREE TRIMMING		\$ -
29	CUT AND KICK POLE - ALL SIZES - IN ADDITION TO POLE PLACEMENT AND REMOVAL	1C	\$198.00
30	OTHER MAKE READY WORK REQUIRED (LIST)		\$ -
	TOTAL MAKE READY WORK CHARGES		

UNIT PRICES FOR SURVEYS AND INSPECTIONS-VERIZON-MASS-SE

12/10/1999

TASK #	TASK DESCRIPTION	ACCT CODE	TOTAL COST
1	PRECONSTRUCTION SURVEYS (PER APPLICATION)		
	1-10 POLES (including travel time for first day)	2M	\$275.00
	11-200 POLES	2M	\$9.90/pole
	TRAVEL TIME (FOR SECOND AND SUBSEQUENT DAYS)(SAME APP) (Based on 75 poles surveyed per day)	2M	\$200/DAY
2	POST-CONSTRUCTION INSPECTION (PER APPLICATION)		
	1-10 POLES (including travel time for first day)	2M	\$275.00
	11-200 POLES	2M	\$8.25/pole
	TRAVEL TIME (FOR SECOND AND SUBSEQUENT DAYS)(SAME APP) (Based on 100 poles surveyed per day)	2M	\$200/DAY
3	SUBSEQUENT INSPECTION (PER APPLICATION)		
	1-10 POLES (including travel time for first day)	2M	\$275.00
	11-200 POLES	2M	\$4.95/pole
	TRAVEL TIME (FOR SECOND AND SUBSEQUENT DAYS)(SAME APP) (Based on 150 poles surveyed per day)	2M	\$200/DAY
4	PERIODIC POLE SURVEYS		
	BASED ON GEOGRAPHIC AREA AND NEGOTIATED UNIT PRICE PER POLE	1M	Not to exceed \$6 PER POLE

UNIT PRICES FOR MAKE READY WORK – VERIZON (VZ) -MASS - WEST

12/10/1999

TASK #	TASK DESCRIPTION	ACCT CODE	TOTAL COST
1A	PLACE 40 FT POLE - 100% VZ OWNED	1C	\$757.90
1B	PLACE 40 FT POLE - 50% VZ OWNED	1C	\$378.95
2A	PLACE 45 FT POLE - 100% VZ OWNED	1C	\$803.00
2B	PLACE 45 FT POLE - 50% VZ OWNED	1C	\$401.50
3A	PLACE OTHER SIZE POLE _____ - 100% VZ OWNED	1C	\$ -
3B	PLACE OTHER SIZE POLE _____ - 50% VZ OWNED	1C	\$ -
4	REMOVE POLE - ALL SIZES - INCLUDING DISPOSAL	1X	\$475.20
5	DEPRECIATION CREDIT	1X	
6	PLACE ANCHOR - ALL TYPES/SIZES	1C	\$390.50
7A	PLACE PA OR PP GUY	1C	\$166.10
7B	PLACE EACH ADDITIONAL PA OR PP GUY (same pole)	1C	\$79.20
8A	PLACE NEW DROP WIRE	42C	\$134.20
8B	PLACE NEW 50 PR TERMINAL	122C	\$283.80
9A	TRANSFER GUY ATTACHMENT	1M	\$166.10
9B	TRANSFER ADDITIONAL GUY ATTACHMENTS (same pole)	1M	\$78.10
10A	MOVE/RAISE/LOWER GUY ATTACHMENT	1M	\$166.10
10B	MOVE/RAISE/LOWER ADD'L GUY ATTACHMENT (same pole)	1M	\$78.10
11A	TRANSFER/MOVE/RAISE/LOWER CABLE (one strand)	2M	\$189.20
11B	TRANSFER/MOVE/RAISE/LOWER ADDITIONAL CABLES (per strand)	2M	\$63.80
12	TRANSFER POLE DIP	2M	\$424.60
13	TRANSFER CROSS-CONNECT CABINET	2M	\$445.50
14A	TRANSFER/MOVE DISTRIBUTION TERMINAL	2M	\$185.90
14B	TRANSFER/MOVE ADDITIONAL DISTRIBUTION TERMINALS (same pole)	2M	\$58.30
15	TRANSFER APPARATUS CASE OR SLACK BOX	2M	\$271.70
16A	TRANSFER LICENSEE CABLE ATTACHMENT	1M	\$152.90
16B	TRANSFER EACH ADD'L LICENSEE CABLE ATT (strands) (same pole)	1M	\$62.70
17A	TRANSFER DROP WIRE	42M	\$114.40
17B	TRANSFER EACH ADDITIONAL DROP WIRE (same pole)	42M	\$27.50
18A	TRANSFER C RURAL WIRE	3M	\$110.00
18B	TRANSFER EACH ADDITIONAL C RURAL WIRE (same pole)	3M	\$26.40
19A	MOVE/RAISE/LOWER DROP WIRE	42M	\$114.40
19B	MOVE/RAISE/LOWER EACH ADDITIONAL DROP WIRE (same pole)	42m	\$27.50
20A	MOVE/RAISE/LOWER C RURAL WIRE	3M	\$110.00
20B	MOVE/RAISE/LOWER EACH ADDITIONAL C RURAL WIRE (same pole)	3M	\$26.40
21A	TRANSFER WIRE TERMINAL	2M	\$112.20
21B	TRANSFER EACH ADDITIONAL WIRE TERMINAL (same pole)	2M	\$24.20
22A	REPLACE ONE DROP WIRE	42M	\$158.40
22B	REPLACE ADDITIONAL DROP WIRES (same pole)	42M	\$70.40
23A	TRANSFER LICENSEE DROP WIRE	42M	\$158.40
23B	TRANSFER EACH ADDITIONAL LICENSEE DROP WIRE (same pole)	42M	\$70.40
24A	REMOVE ANCHOR - ALL SIZES	1X	\$119.90
24B	REMOVE EACH ADDITIONAL ANCHOR (same pole)	1X	\$35.20
25A	REMOVE PA OR PP GUY	1X	\$151.80
25B	REMOVE EACH ADDITIONAL PA OR PP GUY (same pole)	1X	\$67.10
26	SITE PROTECTION (POLICE/TRAFFIC CONTROL)		\$ -
27	ROOM & BOARD		\$ -
28	TREE TRIMMING		\$ -
29	CUT AND KICK POLE - ALL SIZES - IN ADDITION TO POLE PLACEMENT AND REMOVAL	1C	\$212.30
30	OTHER MAKE READY WORK REQUIRED (LIST)		\$ -
	TOTAL MAKE READY WORK CHARGES		

UNIT PRICES FOR SURVEYS AND INSPECTIONS-VERIZON-MASS-WEST 12/10/1999

TASK #	TASK DESCRIPTION	ACCT CODE	TOTAL COST
1	PRECONSTRUCTION SURVEYS (PER APPLICATION)		
	1-10 POLES (including travel time for first day)	2M	\$275.00
	11-200 POLES	2M	\$9.90/pole
	TRAVEL TIME (FOR SECOND AND SUBSEQUENT DAYS)(SAME APP) (Based on 75 poles surveyed per day)	2M	\$200/DAY
2	POST-CONSTRUCTION INSPECTION (PER APPLICATION)		
	1-10 POLES (including travel time for first day)	2M	\$275.00
	11-200 POLES	2M	\$8.25/pole
	TRAVEL TIME (FOR SECOND AND SUBSEQUENT DAYS)(SAME APP) (Based on 100 poles surveyed per day)	2M	\$200/DAY
3	SUBSEQUENT INSPECTION (PER APPLICATION)		
	1-10 POLES (including travel time for first day)	2M	\$275.00
	11-200 POLES	2M	\$4.95/pole
	TRAVEL TIME (FOR SECOND AND SUBSEQUENT DAYS)(SAME APP) (Based on 150 poles surveyed per day)	2M	\$200/DAY
4	PERIODIC POLE SURVEYS		
	BASED ON GEOGRAPHIC AREA AND NEGOTIATED UNIT PRICE PER POLE	1M	Not to exceed \$6 PER POLE

UNIT PRICING SCHEDULE NEW HAMPSHIRE

Data Request STAFF-01

Dated: 09/07/2012

Q-STAFF-001

Attachment 6

Page 41 of 89

UNIT PRICES FOR MAKE READY WORK - VERIZON (VZ) - NH

12/10/1999

TASK #	TASK DESCRIPTION	ACCT CODE	TOTAL COST
1A	PLACE 40 FT POLE - 100% VZ OWNED	1C	\$ 794.20
1B	PLACE 40 FT POLE - 50% VZ OWNED	1C	\$ 397.10
2A	PLACE 45 FT POLE - 100% VZ OWNED	1C	\$ 870.10
2B	PLACE 45 FT POLE - 50% VZ OWNED	1C	\$ 435.05
3A	PLACE OTHER SIZE POLE - 100% VZ OWNED	1C	\$ -
3B	PLACE OTHER SIZE POLE - 50% VZ OWNED	1C	\$ -
4	REMOVE POLE - ALL SIZES - INCLUDING DISPOSAL	1X	\$ 553.30
5	DEPRECIATION CREDIT	1X	
6	PLACE ANCHOR - ALL TYPES/SIZES	1C	\$ 448.80
7A	PLACE PA OR PP GUY	1C	\$ 192.50
7B	PLACE ADDITIONAL PA OR PP GUY (same pole)	1C	\$ 92.40
8A	PLACE NEW DROP WIRE	42C	\$ 150.70
8B	PLACE NEW 50 PR TERMINAL	22C	\$ 326.70
9A	TRANSFER GUY ATTACHMENT	1M	\$ 192.50
9B	TRANSFER ADDITIONAL GUY ATTACHMENTS (same pole)	1M	\$ 90.20
10A	MOVE/RAISE/LOWER GUY ATTACHMENT	1M	\$ 192.50
10B	MOVE/RAISE/LOWER ADD'L GUY ATTACHMENT (same pole)	1M	\$ 90.20
11A	TRANSFER/MOVE/RAISE/LOWER CABLE (one strand)	2M	\$ 214.50
11B	TRANSFER/MOVE/RAISE/LOWER ADDITIONAL CABLES (per strand)	2M	\$ 71.50
12	TRANSFER POLE DIP	2M	\$ 479.60
13	TRANSFER CROSS-CONNECT CABINET	2M	\$ 503.80
14A	TRANSFER/MOVE DISTRIBUTION TERMINAL	2M	\$ 210.10
14B	TRANSFER/MOVE ADDITIONAL DISTRIBUTION TERMINALS (same pole)	2M	\$ 66.00
15	TRANSFER APPARATUS CASE OR SLACK BOX	2M	\$ 309.10
16A	TRANSFER LICENSEE CABLE ATTACHMENT	1M	\$ 176.00
16B	TRANSFER EACH ADD'L LICENSEE CABLE ATT (strands) (same pole)	1M	\$ 66.00
17A	TRANSFER DROP WIRE	42M	\$ 129.80
17B	TRANSFER EACH ADDITIONAL DROP WIRE (same pole)	42M	\$ 31.90
18A	TRANSFER C RURAL WIRE	3M	\$ 129.80
18B	TRANSFER EACH ADDITIONAL C RURAL WIRE (same pole)	3M	\$ 31.90
19A	MOVE/RAISE/LOWER DROP WIRE	42M	\$ 129.80
19B	MOVE/RAISE/LOWER EACH ADDITIONAL DROP WIRE (same pole)	42m	\$ 31.90
20A	MOVE/RAISE/LOWER C RURAL WIRE	3M	\$ 129.80
20B	MOVE/RAISE/LOWER EACH ADDITIONAL C RURAL WIRE (same pole)	3M	\$ 31.90
21A	TRANSFER WIRE TERMINAL	2M	\$ 127.60
21B	TRANSFER EACH ADDITIONAL WIRE TERMINAL (same pole)	2M	\$ 26.40
22A	REPLACE ONE DROP WIRE	42M	\$ 180.40
22B	REPLACE ADDITIONAL DROP WIRES (same pole)	42M	\$ 78.10
23A	TRANSFER LICENSEE DROP WIRE	42M	\$ 129.80
23B	TRANSFER EACH ADDITIONAL LICENSEE DROP WIRE (same pole)	42M	\$ 31.90
24A	REMOVE ANCHOR - ALL SIZES	1X	\$ 140.80
24B	REMOVE EACH ADDITIONAL ANCHOR (same pole)	1X	\$ 40.70
25A	REMOVE PA OR PP GUY	1X	\$ 177.10
25B	REMOVE EACH ADDITIONAL PA OR PP GUY (same pole)	1X	\$ 79.20
26	SITE PROTECTION (POLICE/TRAFFIC CONTROL)		\$ -
27	ROOM & BOARD		\$ -
28	TREE TRIMMING		\$ -
29	CUT AND KICK POLE - ALL SIZES - IN ADDITION TO POLE PLACEMENT AND REMOVAL	1C	\$ 303.60
30	OTHER MAKE READY WORK REQUIRED (LIST)		\$ -
	TOTAL MAKE READY WORK CHARGES		

UNIT PRICING SCHEDULE NEW HAMPSHIRE

Data Request STAFF-01

Dated: 09/07/2012

Q-STAFF-001

Attachment 6

Page 42 of 89

UNIT PRICES FOR SURVEYS AND INSPECTIONS - VERIZON - NH

12/10/1999

TASK #	TASK DESCRIPTION	ACCT CODE	TOTAL COST
1	PRECONSTRUCTION SURVEYS (PER APPLICATION)		
	1-10 POLES (including travel time for first day)	2M	\$275.00
	11-200 POLES	2M	\$9.90/pole
	TRAVEL TIME (FOR SECOND AND SUBSEQUENT DAYS)(SAME APP) (Based on 75 poles surveyed per day)	2M	\$200/DAY
2	POST-CONSTRUCTION INSPECTION (PER APPLICATION)		
	1-10 POLES (including travel time for first day)	2M	\$275.00
	11-200 POLES	2M	\$8.25/pole
	TRAVEL TIME (FOR SECOND AND SUBSEQUENT DAYS)(SAME APP) (Based on 100 poles surveyed per day)	2M	\$200/DAY
3	SUBSEQUENT INSPECTION (PER APPLICATION)		
	1-10 POLES (including travel time for first day)	2M	\$275.00
	11-200 POLES	2M	\$4.95/pole
	TRAVEL TIME (FOR SECOND AND SUBSEQUENT DAYS)(SAME APP) (Based on 150 poles surveyed per day)	2M	\$200/DAY
4	PERIODIC POLE SURVEYS		
	BASED ON GEOGRAPHIC AREA AND NEGOTIATED UNIT PRICE PER POLE	1M	PER POLE

UNIT PRICING SCHEDULE - RHODE ISLAND

Data Request STAFF-01

Dated: 09/07/2012

Q-STAFF-001

Attachment 6

UNIT PRICES FOR MAKE READY WORK - VERIZON (VZ) RHODE ISLAND

12/10/2009 Page 43 of 89

TASK #	TASK DESCRIPTION	ACCT CODE	TOTAL COST
1A	PLACE 40 FT POLE - 100% VZ OWNED	1C	\$ 721.60
1B	PLACE 40 FT POLE - 50% VZ OWNED	1C	\$ 360.80
2A	PLACE 45 FT POLE - 100% VZ OWNED	1C	\$ 805.20
2B	PLACE 45 FT POLE - 50% VZ OWNED	1C	\$ 420.60
3A	PLACE OTHER SIZE POLE - 100% VZ OWNED	1C	\$ -
3B	PLACE OTHER SIZE POLE - 50% VZ OWNED	1C	\$ -
4	REMOVE POLE - ALL SIZES - INCLUDING DISPOSAL	1X	\$ 432.30
5	DEPRECIATION CREDIT	1X	
6	PLACE ANCHOR - ALL TYPES/SIZES	1C	\$ 363.00
7A	PLACE PA OR PP GUY	1C	\$ 149.60
7B	PLACE ADDITIONAL PA OR PP GUY (same pole)	1C	\$ 72.60
8A	PLACE NEW DROP WIRE	42C	\$ 118.80
8B	PLACE NEW 50 PR TERMINAL	22C	\$ 251.90
9A	TRANSFER GUY ATTACHMENT	1M	\$ 151.80
9B	TRANSFER ADDITIONAL GUY ATTACHMENTS (same pole)	1M	\$ 70.40
10A	MOVE/RAISE/LOWER GUY ATTACHMENT	1M	\$ 151.80
10B	MOVE/RAISE/LOWER ADD'L GUY ATTACHMENT (same pole)	1M	\$ 70.40
11A	TRANSFER/MOVE/RAISE/LOWER CABLE (one strand)	2M	\$ 168.30
11B	TRANSFER/MOVE/RAISE/LOWER ADDITIONAL CABLES (per strand)	2M	\$ 56.10
12	TRANSFER POLE DIP	2M	\$ 375.10
13	TRANSFER CROSS-CONNECT CABINET	2M	\$ 394.90
14A	TRANSFER/MOVE DISTRIBUTION TERMINAL	2M	\$ 163.90
14B	TRANSFER/MOVE ADDITIONAL DISTRIBUTION TERMINALS (same pole)	2M	\$ 52.80
15	TRANSFER APPARATUS CASE OR SLACK BOX	2M	\$ 240.90
16A	TRANSFER LICENSEE CABLE ATTACHMENT	1M	\$ 138.60
16B	TRANSFER EACH ADD'L LICENSEE CABLE ATT (strands) (same pole)	1M	\$ 58.30
17A	TRANSFER DROP WIRE	42M	\$ 102.30
17B	TRANSFER EACH ADDITIONAL DROP WIRE (same pole)	42M	\$ 23.10
18A	TRANSFER C RURAL WIRE	3M	\$ 102.30
18B	TRANSFER EACH ADDITIONAL C RURAL WIRE (same pole)	3M	\$ 23.10
19A	MOVE/RAISE/LOWER DROP WIRE	42M	\$ 102.30
19B	MOVE/RAISE/LOWER EACH ADDITIONAL DROP WIRE (same pole)	42m	\$ 23.10
20A	MOVE/RAISE/LOWER C RURAL WIRE	3M	\$ 102.30
20B	MOVE/RAISE/LOWER EACH ADDITIONAL C RURAL WIRE (same pole)	3M	\$ 23.10
21A	TRANSFER WIRE TERMINAL	2M	\$ 99.00
21B	TRANSFER EACH ADDITIONAL WIRE TERMINAL (same pole)	2M	\$ 22.00
22A	REPLACE ONE DROP WIRE	42M	\$ 140.80
22B	REPLACE ADDITIONAL DROP WIRES (same pole)	42M	\$ 61.60
23A	TRANSFER LICENSEE DROP WIRE	42M	\$ 102.30
23B	TRANSFER EACH ADDITIONAL LICENSEE DROP WIRE (same pole)	42M	\$ 23.10
24A	REMOVE ANCHOR - ALL SIZES	1X	\$ 108.90
24B	REMOVE EACH ADDITIONAL ANCHOR (same pole)	1X	\$ 33.00
25A	REMOVE PA OR PP GUY	1X	\$ 137.50
25B	REMOVE EACH ADDITIONAL PA OR PP GUY (same pole)	1X	\$ 62.70
26	SITE PROTECTION (POLICE/TRAFFIC CONTROL)		\$ -
27	ROOM & BOARD		\$ -
28	TREE TRIMMING		\$ -
29	CUT AND KICK POLE - ALL SIZES - IN ADDITION TO POLE PLACEMENT AND REMOVAL	1C	\$ 191.40
30	OTHER MAKE READY WORK REQUIRED (LIST)		\$ -
	TOTAL MAKE READY WORK CHARGES		

UNIT PRICING SCHEDULE - RHODE ISLAND

Data Request STAFF-01
 Dated: 09/07/2012
 Q-STAFF-001
 Attachment 6
 Page 44 of 89

UNIT PRICES FOR SURVEYS AND INSPECTIONS -VERIZON- RHODE ISLAND

12/10/1999

TASK #	TASK DESCRIPTION	ACCT CODE	TOTAL COST
1	PRECONSTRUCTION SURVEYS (PER APPLICATION)		
	1-10 POLES (including travel time for first day)	2M	\$275.00
	11-200 POLES	2M	\$9.90/pole
	TRAVEL TIME (FOR SECOND AND SUBSEQUENT DAYS)(SAME APP) (Based on 75 poles surveyed per day)	2M	\$200/DAY
2	POST-CONSTRUCTION INSPECTION (PER APPLICATION)		
	1-10 POLES (including travel time for first day)	2M	\$275.00
	11-200 POLES	2M	\$8.25/pole
	TRAVEL TIME (FOR SECOND AND SUBSEQUENT DAYS)(SAME APP) (Based on 100 poles surveyed per day)	2M	\$200/DAY
3	SUBSEQUENT INSPECTION (PER APPLICATION)		
	1-10 POLES (including travel time for first day)	2M	\$275.00
	11-200 POLES	2M	\$4.95/pole
	11-200 POLES	2M	\$200/DAY
	TRAVEL TIME (FOR SECOND AND SUBSEQUENT DAYS)(SAME APP) (Based on 150 poles surveyed per day)		
4	PERIODIC POLE SURVEYS		
	BASED ON GEOGRAPHIC AREA AND NEGOTIATED UNIT PRICE PER POLE	1M	PER POLE

UNIT PRICES FOR SURVEYS AND INSPECTIONS-VERIZON - MAINE			12/10/1999
TASK #	TASK DESCRIPTION	ACCT CODE	TOTAL COST
1	PRECONSTRUCTION SURVEYS (PER APPLICATION)		
	1-10 POLES (Including travel time for first day)	2M	\$275.00
	11-200 POLES	2M	\$9.90/pole
	TRAVEL TIME (FOR SECOND AND SUBSEQUENT DAYS)(SAME APP) (Based on 75 POLES surveyed per day)	2M	\$200/DAY
2	POST-CONSTRUCTION INSPECTION (PER APPLICATION)		
	1-10 POLES (Including travel time for first day)	2M	\$275.00
	11-200 POLES	2M	\$8.25/pole
	TRAVEL TIME (FOR SECOND AND SUBSEQUENT DAYS)(SAME APP) (Based on 100 POLES surveyed per day)	2M	\$200/DAY
3	SUBSEQUENT INSPECTION (PER APPLICATION)		
	1-10 POLES (Including travel time for first day)	2M	\$275.00
	11-200 POLES	2M	\$4.95/pole
	TRAVEL TIME (FOR SECOND AND SUBSEQUENT DAYS)(SAME APP) (Based on 150 POLES surveyed per day)	2M	\$200/DAY
4	PERIODIC POLE SURVEYS		
	BASED ON GEOGRAPHIC AREA AND NEGOTIATED UNIT PRICE PER POLE	1M	PER POLE

12/10/1999
 Data Request STAFF-01
 Date: 09/07/2012
 STAFF-001
 Attachment 6
 Page 46 of 89

UNIT COST FOR SURVEY AND MAKE READY WORK PERFORMED BY VERIZON - VERMONT

UNIT COSTS FOR SURVEYS AND INSPECTIONS - VERMONT

Data Request STAFF-01

2/2/2009: 09/07/2012

Q-STAFF-001

Attachment 6

Page 48 of 89

TASK #	TASK DESCRIPTION	ACCT CODE	TOTAL COST
1	PRECONSTRUCTION SURVEYS (PER APPLICATION)		
	1-10 POLES (Including travel time for first day)	2M	\$250.00
	11-200 POLES	2M	\$9.00/POLE
	TRAVEL TIME (FOR SECOND AND SUBSEQUENT DAYS)(SAME APP) (Based on 75 POLES surveyed per day)	2M	\$150/DAY
2	POST-CONSTRUCTION INSPECTION (PER APPLICATION)		
	1-10 POLES (Including travel time for first day)	2M	\$250.00
	11-200 POLES	2M	\$7.50/POLE
	TRAVEL TIME (FOR SECOND AND SUBSEQUENT DAYS)(SAME APP) (Based on 100 POLES surveyed per day)	2M	\$150/DAY
3	SUBSEQUENT INSPECTION (PER APPLICATION)		
	1-10 POLES (Including travel time for first day)	2M	\$250.00
	11-200 POLES	2M	\$4.50/POLE
	TRAVEL TIME (FOR SECOND AND SUBSEQUENT DAYS)(SAME APP) (Based on 150 POLES surveyed per day)	2M	\$150/DAY
4	PERIODIC POLE SURVEYS		
	BASED ON GEOGRAPHIC AREA AND NEGOTIATED UNIT PRICE PER POLE	1M	PER POLE

APPENDIX II

NOTICE ADDRESSES

Licensor – Verizon New England Inc.

All Notices are to be sent to: Verizon New England Inc.
Manager - License Administration Group
185 Franklin Street, Room 503
Boston, Massachusetts 02110
Attention: Patricia Mazzacone
Title: Specialist, License Administration
Tel: 617-743-5724
Fax: (617) 743-8785

Licensor – PUBLIC SERVICE COMPANY OF NEW HAMPSHIRE

All Notices are to be sent to: Public Service Company of New Hampshire
60 West Pennacook St.
Manchester, NH
Attention: Russel D. Johnson
Title: Supervisor, Distribution Projects
Tel: 603-634-3440
Fax: 603-634-3550

Licensor – Freedom Ring Communications, LLC. d/b/a Bayring Communications

All Notices will be sent to the contacts as listed in the attached Customer
Profile form:

For Notices and Renewals:

Steve Wengert
Attn: Legal Department
359 Corporate Dr.
Portsmouth, NH 03801

For Invoices and Licensing:

Steve Wengert
Attn: Billing Department
359 Corporate Dr.
Portsmouth, NH 03801

A blank form may also be utilized to provide Verizon with updated notice
addresses as necessary. Please send updated information to:

Verizon New England Inc.-
Specialist, License Administration Group
185 Franklin St., Room 503
Boston, MA 02110

DATE: _____

Customer Profile

Person Negotiating Agreement _____

(name of person we may contact if there are questions)

LICENSEE NAME _____ State of Incorporation _____

(legal company name in which you are registered in the state to do business)

Municipality(ies) for which contacts below apply:

(Please use multiple pages as required)

Address where Legal Notices are to be sent:		Address where Insurance Notices are to be sent:	
Contact Name		Contact Name	
Title		Title	
Address		Address	
City, State, Zip		City, State, Zip	
Attention:		Attention:	
Tel #	Fax #	Tel #	Fax #
E-mail address		E-mail address	
Address where Automatic License Requests are to be sent:		Address where Poles/ Conduit Rental Bills are to be sent:	
Contact Name		Contact Name	
Title		Title	
Address		Address	
City, State, Zip		City, State, Zip	
Attention:		Attention:	
Tel #	Fax #	Tel #	Fax #
E-mail address		E-mail address	
Address where Transfer Notices are to be sent:		Person to notify in emergency of damaged plant:	
Contact Name		Contact Name	
Title		Title	
Address		Address	
City, State, Zip		City, State, Zip	
Tel #	Fax #	Tel #	Fax #
E-mail address		E-mail address	

Please utilize this form to update as necessary, and send to:

This form has been completed by: _____

Telephone No.: _____

VERIZON NE - License Administration

185 Franklin St., Room 503

Boston, MA 02110

Tel # 1 800 641-2299, Fax # 1 617 743-8785

APPENDIX III

State and Municipalities Covered by this Agreement
broken down by
Planning Manager's Area

Massachusetts

The following list includes all municipalities served by Verizon from the State of Massachusetts with the exception of those served over the boundary from Vermont and Rhode Island. See Vermont and Rhode Island for municipalities served from Vermont and Rhode Island. Other municipalities are served by independent Telephone Companies.

Metro-South Ma (Boston Metro Areas)

BOSTON *	DORCHESTER	MILTON	SCITUATE *
BRAINTREE	DOVER *	NORWELL *	SOMERVILLE *
BROOKLINE*	HINGHAM	NORWOOD *	WEST ROXBURY
CANTON *	HOLBROOK *	QUINCY	WESTWOOD
COHASSET	HULL	RANDOLPH	WEYMOUTH
DEDHAM *	MATTAPAN	ROSLINDALE	

North Ma (Cambridge-Somerville & Brookline-Newton Areas)

ARLINGTON	CAMBRIDGE	MEDFORD *	WATERTOWN
BEDFORD *	CHESTNUT STREET	NATICK *	WAYLAND *
BELMONT	DEDHAM *	NEEDHAM	WELLESLEY *
BOSTON *	DOVER *	NEWTON	WESTON
BROOKLINE *	LEXINGTON	SOMERVILLE *	WINCHESTER
BURLINGTON *	LINCOLN *	WALTHAM	WOBURN *

Northeast Ma (Lawrence-Lowell & Malden-North Shore Areas)

AMESBURY	GLOUCESTER	MUNIS	TOPSFIELD
ANDOVER	GROTON *	NAHANT	TYNGSBORO
ARBLEHEAD	GROVELAND	NEWBURY	WAKEFIELD
BEDFORD *	HAMILTON	NEWBURYPORT	WENHAM
BEVERLY	HAVERHILL	NORTH ANDOVER	WEST BOXFORD
BILLERICA	IPSWICH	NORTH READING	WEST NEWBURY
BOSTON *	LAWRENCE	PEABODY	WESTFORD *
BOXFORD	LOWELL	PEPPERELL *	WILMINGTON
BURLINGTON *	LYNN	READING	WINTHROP
CARLISLE *	LYNNFIELD	REVERE	WOBURN *
CHELMSFORD	MALDEN	ROCKPORT	
CHELSEA	MANCHESTER	ROWLEY	
DANVERS	MARBLEHEAD	SALEM	also Includes...
DRACUT	MEDFORD *	SALISBURY	East Kensington, NH *
DUNSTABLE *	MELROSE	SAUGUS	Hampton, NH *
ESSEX	MERRIMAC	STONEHAM	Kensington, NH *
EVERETT	METHUEN	SWAMPSCOTT	Seabrook, NH *
GEORGETOWN	MIDDLETON	TEWKSBURY	South Hampton , NH

Massachusetts Continued...

Southeast Ma (Brockton & Cape Areas)

ABINGTON	DIGHTON	MARION	ROCKLAND
ACUSHNET	DUXBURY	MARSHFIELD	SANDWICH
AQUINNA	EAST BRIDGEWATER	MASHPEE	SCITUATE *
AVON	EASTHAM	MATTAPOISETT	SHARON *
BARNSTABLE	EASTON	MIDDLEBORO	SOMERSET *
BASS RIVER	EDGARTOWN	NANTUCKET	STOUGHTON
BERKLEY	FAIRHAVEN	NEW BEDFORD	SWANSEA *
BOURNE	FALL RIVER	NORTON *	TAUNTON
BREWSTER	FALMOUTH	NORWELL *	TISBURY
BRIDGEWATER	FREETOWN	OAK BLUFFS	TRURO
BROCKTON	GAY HEAD	ORLEANS	WAREHAM
BUZZARDS BAY	HALIFAX	PEMBROKE	WELLFLEET
CARVER	HANOVER	PLYMOUTH	WEST BRIDGEWATER
CHATHAM	HANSON	PLYMPTON	WEST TISBURY
CHILMARK	HARWICH	PROVINCETOWN	WESTPORT
CUTTYHUNK ISLAND	HOLBROOK *	RAYNHAM	WHITMAN
DARTHMOUTH	KINGSTON	REHOBOTH *	YARMOUTH
DENNIS	LAKEVILLE	ROCHESTER	

Central Ma (Framingham & Worcester Areas)

ACTON	DUDLEY	LUNENBURG	OXFORD
ASHBURNHAM	DUNSTABLE *	MANSFIELD	PAXTON
ASHBY	EAST BROOKFIELD	MARLBORO	PEPPERELL *
ASHLAND	EAST DOUGLAS	MAYNARD	PETERSHAM
ATHOL	ERVING *	MEDFIELD	PHILLIPSTON
ATTLEBORO *	FITCHBURG	MEDWAY	PLAINVILLE
AUBURN	FOXBORO	MENDON *	PRINCETON
AYER	FRAMINGHAM	MILBURY	REHOBOTH *
BARRE	FRANKLIN	MILFORD	ROYALSTON
BEDFORD *	GARDNER	MILLBURY	RUTLAND
BELLINGHAM *	GRAFTON	MILLIS	SHARON *
BERLIN	GROTON *	NATICK *	SHERBORN
BOLTON	HARVARD	NEW SALEM *	SHIRLEY
BOXBORO	HOLDEN	NORFOLK	SHREWSBURY
BOYLSTON	HOLLISTON	NORTH ATTLEBORO *	SHUTESBURY *
BRIMFIELD *	HOPEDALE	NORTH BROOKFIELD	SOUTHBORO
BROOKFIELD	HOPKINTON	NORTH GRAFTON	SOUTHBRIDGE
CANTON *	HUBBARDSTON	NORTHBORO	SPENCER
CARLISLE *	HUDSON	NORTHBRIDGE	STERLING
CHARLTON	LANCASTER	NORTHFIELD *	STOW
CLINTON	LEICESTER	NORTON *	STURBRIDGE
CONCORD	LEOMINSTER	NORWOOD *	SUDBURY
DOUGLAS	LINCOLN *	OAKHAM	SUTTON
DOVER *	LITTLETON	ORANGE	TEMPLETON

Massachusetts Continued...

Central Ma (Framingham & Worcester Areas) Continued...

TOWNSEND	WAYLAND *	WEST BROOKFIELD *	WORCESTER
UPTON	WEBSTER	WESTBORO	WRENTHAM *
UXBRIDGE	WELLESLEY *	WESTFORD *	
WALPOLE	WENDELL *	WESTMINSTER	
WARWICK	WEST BOYLSTON	WINCHENDON	

Western Ma (413 Area)

ADAMS	GILL	MONTEREY	SPRINGFIELD
AGAWAM	GOSHEN	MONTGOMERY	STOCKBRIDGE
ALFORD	GRANBY	MT WASHINGTON	SUNDERLAND
AMHERST	GRANVILLE	NEW ASHFORD	TOLLAND
ASHFIELD	GREAT BARRINGTON	NEW BRAINTREE	TYRINGHAM
BECKET	GREENFIELD	NEW MARLBORO	WALES
BELCHERTOWN	HADLEY	NEW SALEM *	WARE
BERNARDSTON	HAMPDEN	NORTH ADAMS	WARREN
BLANDFORD	HANCOCK	NORTHAMPTON	WASHINGTON
BLANFORD	HARDWICK	NORTHFIELD *	WENDELL *
BRIMFIELD *	HATFIELD	OTIS	WEST BROOKFIELD *
BUCKLAND	HAWLEY	PALMER	WEST SPRINGFIELD
CHARLEMONT	HEATH	PELHAM	WEST STOCKBRIDGE
CHESHIRE	HINSDALE	PERU	WESTFIELD
CHESTER	HOLLAND	PITTSFIELD	WESTHAMPTON
CHESTERFIELD	HOLYOKE	PLAINFIELD	WHATELY
CHICOPEE	HUNTINGTON	RICHMOND	WILBRAHAM
CLARKSBURG	LANESBORO	ROWE	WILLIAMSBURG
COLRAIN	LEE	RUSSELL	WILLIAMSTOWN
CONWAY	LENOX	SANDISFIELD	WINDSOR
CUMMINGTON	LEVERETT	SAVOY	WORTHINGTON
DALTON	LEYDEN	SHEFFIELD	
DEERFIELD	LONGMEADOW	SHELBURNE	also includes...
EAST LONGMEADOW	LUDLOW	SHELBURNE FALLS	STAMFORD, VT
EASTHAMPTON	MIDDLEFIELD	SHUTESBURY *	SOUTH GUILFORD, VT *
EGREMONT	MONSON	SOUTH HADLEY	
ERVING *	MONTAGUE	SOUTHAMPTON	
FLORIDA	MONTAGUE L D	SOUTHWICK	

Maine

The following list includes all municipalities served by Verizon from the State of Maine with the exception of those served over the boundary from New Hampshire. See New Hampshire for municipalities served from New Hampshire. Other municipalities are served by independent Telephone Companies.

ABBOT	BOW COLL GRANT	CHERRYFIELD	DREW PLT
ACAD GRANT	BOWDOIN	CHESTER	DURHAM
ACTON *	BOWDOINHAM	CHESTERVILLE	DYER PLT
ADAMSTOWN TWP	BOWERBANK	CHINA	EAST DIXFIELD
ADDISON	BRADFORD	CLIFTON	EAST FRANKLIN
ALEXANDER	BRADLEY	CLINTON	EAST MACHIAS
ALFRED	BREWER	CODYVILLE PLT	EAST MILLINOCKET
ALNA	BRIDGEWATER	COLUMBIA	EAST MOXIE TWP
ALTON	BRIDGTON	COLUMBIA FALLS	EAST NEWPORT
AMITY	BROOKLIN	CONCORD	EASTBROOK
ANDOVER	BROOKS	CONNOR TWP	EASTON
ANSON	BROOKSVILLE	COOPER	EASTPORT
ARGYLE	BROOKTON	COREA	EDDINGTON
ARROWSIC	BROWNVILLE	CORINA	EDGEComb
ARUNDEL	BROWNVILLE JUCTION	CORINNA	EDGEComE
ASHLAND	BRUNSWICK	CORINTH	EDINBURG
ATKINSON	BUCKS HARBOR	CORNISH	EDMUNDS TWP
ATTEAN TWP	BUCKSPORT	CORNVILLE	EFFINGHAM
AUBURN	BURLINGTON	COSTIGAN	ELIOT *
AUGUSTA	BURNHAM	COUSINS	ELLIOTSVILLE TWP
AVON	BUXTON	CRANBERRY ISLES	ELLSWORTH
BAILEYVILLE	BYRON	CRAWFORD	ENFIELD
BALD MTN	CALAIS	CROUSVILLE	ETNA
BALDWIN	CAMDEN	CUMBERLAND	EXETER
BANCROFT	CANAAN	CUSHING	FAIRFIELD
BAR HARBOR	CANTON	CUTLER	FALMOUTH
BARING PLT	CAPE ELIZABETH	CYR PLT	FARMINGDALE
BATH	CAPE PORPOISE	DALLAS	FARMINGTON
BEALS	CARATUNK	DAMARISCOTTA	FAYETTE
BEARNARD PLT	CARDVILLE	DANFORTH	FOREST CITY TWP
BEAVER COVE PLT	CARIBOU	DARK HARBOR	FOREST TWP
BELFAST	CARMEL	DAVIS PLT	FORKSTOWN
BELGRADE	CARTHAGE	DAYTON	FORT FAIRFIELD
BENTON	CARY PLT	DEDHAM	FOWLER TWP
BERNARD	CASTINE	DEER ISLE	FOXCROFT
BERWICK *	CASTLE HILL	DENMARK	FRANKFORT
BIDDEFORD	CASWELL	DENNISTOWN PLT	FRANKLIN
BIG SQUAW TWP	CASWELL PLT	DENNYVILLE	FREEPORT
BINGHAM	CENTERVILLE	DERBY	FRENCHTOWN TWP
BLAINE	CHAPMAN	DETROIT	FRENCHVILLE
BLANCHARD PLT	CHARLESTON	DEXTER	FRIENDSHIP
BLUE HILL	CHARLOTTE	DIXFIELD	FRIENDSHIP EAST
BOOTHBAY	CHELSEA	DRESDEN	GARDINER

Maine Continued...

GARFIELD	INDUSTRY	LONG POND	MT DESERT
GARLAND	ISLEBORO	LOVELL	MT VERNON
GEORGETOWN	JACKMAN	LOWER CUPSUPTIC TWP	NAPLES
GLENBURN	JACKSONVILLE	LUBEC	NASHVILLE PLT
GLENWOOD PLT	JAY	LUDLOW	NEW GLOUCESTER
GOODWINS MILLS	JEFFERSON	LYMAN	NEW LIMERICK
GORHAM	JOHNSON MOUNTAIN	MACHIAS	NEW SHARON
GOULDSBORO	JONESBORO	MACHIASPORT	NEW SWEDEN
GRAND ISLE	JONESPORT	MACWAHOC PLT	NEW VINEYARD
GRAND LAKE STREAM	KATAHDIN IRON W	MADAWASKA	NEWBURGH
GRAY	KEEGAN	MADISON	NEWCASTLE
GREAT CHEABEAG	KENDUSKEAG	MADRID	NEWFIELD
GREAT WASS	KENNEBUNK	MANCHESTER	NEWPORT
GREENBUSH	KENNEBUNKPORT	MANSET	NEWRY
GREENE	KINEO TWP	MAPLETON	NOBLEBORO
GREENFIELD	KINGSBURY PLT	MARION	NORCROSS
GREENING	KITTERY *	MARION TWP	NORRIDGEWOCK
GREENVILLE	KOKADJO	MARS HILL	NORTH BERWICK
GRINDSTONE TWP	KOSSUTH	MARSHFIELD	NORTH BROOKSVILLE
GUILFORD	LAGRANG	MASARDIS	NORTH DEER ISLE
HALLOWELL	LAKE VIEW PLT	MATTAWANKEAG	NORTH DEERING
HAMDEN	LAKEVIEW PLT	MATTISCONTIS TWP	NORTH EAST HARBOR
HAMLIN	LAMBERT LAKE	MECHANIC FALLS	NORTH HAVEN
HAMMOND	LAMOINE	MEDDYBEMPS	NORTH PERRY
HANCOCK	LANG TWP	MEDFORD	NORTH SANFORD
HANOVER	LARRABEE	MEDWAY	NORTH WHITEFIELD
HARFORDS PT TWP	LEBANON	MEDWAY TWP	NORTH YARMOUTH
HARPSWELL	LEVANT	MEXICO	NORTH YARMOUTH
HARRINGTON	LEWISTON	MILBRIDGE	NORTHFIELD
HARRISON	LILY BAY TWP	MILFORD	NORTHPORT
HARTLAND	LIMERICK	MILLINOCKET	NORWAY
HAYNESVILLE	LIMESTONE	MILLTOWN	OAKLAND
HEBRON	LIMINGTON	MILO	OGUNQUIT
HERMON	LINCOLN *	MILTON	OLD ORCHARD
HERSEY	LINCOLNVILLE	MINOT	OLD TOWN
HERSHEYTOWN TWP	LINNEUS	MISERY GORE	ORANEVILLE
HIRAM	LISBON	MISERY TWP	ORIENT
HODGDON	LISBON FALLS	MOLUNKUS	ORLAND
HOLDEN	LISTONE	MONHEGAN	ORNEVILLE
HOPE	LITCHFIELD	MONROE	ORONO
HOPKINS ACAD GRANT	LITTLE DEER ISLE	MONSON	ORRINGTON
HOULTON	LITTLE JOHNS	MONTICELLO	OTIS
HOWLAND	LITTLE SQUAW TWP	MOOSE RIVER	OTISFIELD
HUDSON	LITTLETON	MORO PLT	OWLS HEAD
INDIAN ISLAND	LIVERMORE	MOSCOW	OXBOW PLT
INDIAN PURCHASE	LIVERMORE FALLS	MOUNT DESERT	OXFORD
INDIAN TWP	LONG A TWP	MOXIE GORE	PALMYRA

Maine Continued...

PARIS	ROME	STANDISH	WASHINGTON TWP
PARKMAN	ROQUE BLUFFS	STARKS	WATERBORO
PARLIN POND	ROXBURY	STETSONTOWN TWP	WATERFORD
PARSONFIELD	RUMFORD	STEBEN	WATERVILLE
PASSADUMKEAG	SABATTUS	STILLWATER	WAYNE
PATTEN	SACO	STOCKHOLM	WELD
PEAKS ISLAND	SANDBAR TRACT	STOCKTON	WELLS
PEMBROKE	SANDY BAY	STONEHAM	WESLEY
PENOBSCOT	SANDY RIVER PLT	STONINGTON	WEST BATH
PERHAM	SANFORD	STRONG	WEST BROOKSVILLE
PERKINS TWP SI	SANGERVILLE	SULLIVAN	WEST ENFIELD
PERRY	SAPLING TWP	SUNSET	WEST FORKS PLT
PERU	SARGENTVILLE	SUNSHINE	WEST GARDINER
PHILLIPS	SCARBOROUGH	SURRY	WEST GOULDSBORO
PHIPPSBURG	SEAL HARBOR	SUTTON	WEST HARRINGTON
PITTSFIELD	SEARSPORT	SWANVILLE	WEST JONESPORT
PITTSTON	SEBAGO	SWEDEN	WEST NEWFIELD
PLEASANT POINT	SEBEC	SYMRNA	WEST PARIS
PLEASANT RIDGE PLT	SEDGWICK	TALMADGE	WESTBROOK
PLYMOUTH	SHAPLEIGH	TAUNTON & RAYNHAM	WESTFIELD
POLAND	SHAPLEIGHT	TEMPLE	WESTMANLAND PLT
PORT SLYDE	SHIRLEY	TENANTS HARBOR	WESTON
PORTAGE LAKE	SIDNEY	THE FORKS	WESTPORT
PORTER	SKOWHEGAN	THOMASTON	WHITEFIELD
PORTLAND	SOLDIERTOWN TWP	TOMHEGAN TWP	WHITING
POWNAI	SOLON	TOPSFIELD	WHITNEYVILLE
PRENTISS PLT	SOMERVILLE	TOPSHAM	WILLIAMSBURG PLT
PRESQUE ISLE	SONESVILLE	TREMONT	WILLIMANTIC
PRINCETON	SORRENTO	TRENTON	WILTON
PROSPECT	SOUTH ADDISON	TRESCOTT TWP	WINDHAM
PROSPECT HARBOR	SOUTH BERWICK	TURNER	WINDSOR
QUODDY	SOUTH BROOKSVILLE	UPPER ENCHANTED	WINN
RANDOLPH	SOUTH LAGRANGE	VAN BUREN	WINSLOW
RANGELEY	SOUTH PORTLAND	VANCEBORO	WINTER HARBOR
RANGELEY PLT	SOUTH THOMASTON	VASSALBORO	WINTERPORT
RAYMOND	SOUTH WEST HARBOR	VEAZIE	WINTHROP
READFIELD	SOUTHPORT	VERONA	WISCASSET
REED	SPRINGVALE	VINAL HAVEN	WOODLAND
RICHMOND	SQUAPAN	WADE	WOODSTOCK
RIPLEY	SQUAPAN TWP	WAITE	WOODVILLE
ROBBINSON	SRV FR MCDAM N B	WALDO	WOOLWICH
ROBINSONS	ST AGATHA	WALDOBORO	YARMOUTH
ROCKLAND	ST ALBANS	WALES	YORK
ROCKPORT	ST DAVID	WALTHAM	YORK BEACH
ROCKWOOD	ST GEORGE	WARREN	
ROCKWOOD STRIP	STACYVILLE	WASHBURN	

New Hampshire

The following list includes all municipalities served by Verizon from the State of New Hampshire with the exception of those served over the boundary from Massachusetts and Vermont. See Massachusetts and Vermont for municipalities served from Massachusetts and Vermont. Other municipalities are served by independent Telephone Companies.

ACTON	CLAREMONT	GILMANTON	LEBANON *
ACWORTH	CLARKSVILLE	GILMANTON IW	LEE
ALBANY	COLEBROOK	GILSUM	LEMPSTER
ALEXANDRIA	COLUMBIA	GLENDALE	LINCOLN
ALLENSTOWN	CONCORD	GOFFSTOWN	LISBON
ALSTEAD	CONWAY	GORHAM	LITCHFIELD
ALTON	CORNISH *	GOSHEN	LITTLETON
AMHERST	CROYDON	GRAFTON	LONDONDERRY
ANDOVER	CTR HARBOR	GRANTHAM	LOUDON
ANTRIM	CTR SANDWICH	GREENFIELD	LYMAN
ASHLAND	DALTON	GREENLAND	LYME *
ATKINSON	DANBURY	GREENVILLE	LYNDEBORO
AUBURN	DANVILLE	GROTON	LYNDEBOROUGH
BARNSTEAD	DEERFIELD	GROVETON	MADBURY
BARRINGTON	DERRY	HAMPSTEAD	MADISON
BARTLETT	DORCHESTER	HAMPTON *	MANCHESTER
BATH	DOVER	HAMPTON FALLS	MARLBORO
BEDFORD	DUBLIN	HANCOCK	MARLBOROUGH
BELMONT	DUMMER	HANOVER	MARLOW
BENNINGTON	DUNBARTON	HARRISVILLE	MASON
BENTON	DURHAM	HARTS LOCA	MEREDITH
BERLIN	E KINGSTON	HAVERHILL	MERRIMACK
BETHLEHEM	EAST HAMPSTEAD	HEBRON	MIDDLETON
BOSCAWEN	EAST KINGSTON *	HILL	MILAN
BOW	EAST SWANSEY	HILLSBORO	MILFORD
BRENTWOOD	EASTON	HINSDALE *	MILTON
BRIDGEWATER	EATON	HOLDERNESS	MILTON FALLS
BRISTOL	EFFINGHAM	HOLLIS	MONROE *
BROOKFIELD	ELLSWORTH	HOOKSETT	MONT VERNON
BROOKLINE	ENFIELD	HOPKINTON	MOULTONBOROUGH
CAMPTON	EPPING	HUDSON	N CONWAY
CANAAN	EPSOM	JACKSON	N HAMPTON
CANDIA	ERROL	JAFFREY	N HAVERHILL
CANTERBURY	EXETER	JEFFERSON	NASHUA
CARROLL	FARMINGTON	KEENE	NELSON
CENTER HARBOR	FITZWILLIAM	KENSINGTON	NEW BOSTON
CENTER OSS�PEE	FRANCESTOWN	KINGSTON *	NEW CASTLE
CHARLESTOWN	FRANCONIA	KITTERY	NEW HAMPTON
CHATHAM	FRANKLIN	LACONIA	NEW IPSWICH
CHESTER	FREEDOM	LANCASTER	NEW LONDON
CHESTERFIELD *	FREMONT	LANDAFF	NEWBURY
CHICHESTER	GILFORD	LANGDON	NEWFIELDS

New Hampshire Continued...

NEWINGTON	PLAISTOW	SOUTH NASHUA	TUFTONBORO
NEWMARKET	PLYMOUTH	SPOFFORD	TWIN MOUNTAIN
NEWPORT	PORTSMOUTH	SPRINGFIELD	UNITY
NEWTON	RANDOLPH	STAFFORD	W STEWARTSTOWN
NORTH CUMBERLAND	RAYMOND	STARK	WAKEFIELD
NORTH STRATFORD	RICHMOND	STEWARTSTOWN	WALPOLE *
NORTH UMBERLAND	RINDGE	STODDARD	WARREN
NORTH WOODSTOCK	ROCHESTER	STRAFFORD	WASHINGTON
NORTHFIELD	ROLLINGSFORD	STRATFORD	WATERVILLE VALLEY
NORTHUMBERLAND	ROXBURY	STRATHAM	WEATHERSFIELD'
NORTHWOOD	RUMNEY	SUGAR HILL	WEIRS
NORWICH	RYE	SULLIVAN	WENTWORTH
NOTTINGHAM	RYE BEACH	SUNAPEE	WEST LEBANON
ORANGE	S NASHUA	SUNCOOK	WEST MORELAND
OSSIPEE	SALEM	SURRY	WEST SWANSEY
PELHAM	SALISBURY	SUTTON	WESTMORELAND
PEMBROKE	SANBORNTON	SWANSEY	WHITEFIELD
PENACOOK	SANBORNVILLE	SWANZEY	WILMOT
PETERBOROUGH	SANDOWN	TAMWORTH	WILTON
PIERMONT *	SANDWICH	TEMPLE	WINCHESTER
PIKE	SEABROOK *	THETFORD	WINDHAM
PITTSBURG	SHARON	THORNTON	WOLFEBORO
PITTSFIELD	SHELBURNE	TILTON	WOODSTOCK
PLAINFIELD *	SOMERSWORTH	TROY	WOODSVILLE

also includes...

ACTON, ME *	BLOOMFIELD, VT	MAIDSTONE, VT
BERWICK, ME *	BRUNSWICK, VT	NEWBURY, VT *
ELIOT, ME *	CANAAN, VT	NORWICH, VT *
KITTERY, ME*	GRANBY, VT	RYEGATE, VT *
LINCOLN, ME *	GUILDHALL, VT	THETFORD, VT *
MAGALLOWAY, ME	LEMINGTON, VT	VICTORY, VT *
NORTH OXFORD, ME	LUNENBURG, VT *	WESTMINSTER, VT *

Rhode Island

The following list includes all municipalities served by Verizon from the State of Rhode Island.

ASHTON	EXETER	NORTH KINGSTON	TIVERTON
BARNGTON	FOSTER	NORTH PROVIDENCE	WARREN
BRISTOL	GLOUCESTER	NORTH SMITHFIELD	WARWICK
BURLLVILLE	GREENVILLE	PASCOAG	WEST GREENWICH
CAROLINA	HOPKINTON	PAWTUCKET	WEST WARWICK
CENT FALLS	JAMESTOWN	PORTSMOUTH	WESTERLY
CENTREDALE	JOHNSTON	PROVIDENCE	WESTPORT
CHARLESTOWN	LINCOLN	PRUDENCE ISLAND	WOONSOCKET
COVENTRY	LITTLE COMPTON	RICHMOND	
CRANSTON	MIDDLETOWN	RIVERSIDE	
CUMBERLAND	NARRAGANSETT	SCITUATE	
EAST GREENWICH	NEW SHOREHAM	SMITHFIELD	
EAST PROVIDENCE	NEWPORT	SOUTH KINGSTON	

also includes...

ATTLEBORO, MA *	NORTH ATTLEBORO, MA *
BELLINGHAM, MA *	REHOBOTH, MA *
BLACKSTONE, MA	SEEKONK, MA
MENDON, MA *	SWANSEA, MA *
MILLVILLE, MA	WRENTHAM, MA *

Vermont

The following list includes all municipalities served by Verizon from the State of Vermont with the exception of those served over the boundary from Massachusetts and New Hampshire. See Massachusetts and New Hampshire for municipalities served from Massachusetts and New Hampshire. Other municipalities are served by independent Telephone Companies.

ALBANY	E MONTPELIER	LEICHESTER	READSBORO
ARLINGTON	EAST HAVEN	LONDONDERRY	RICHFORD
BAKERFIELD	EDEN	LOWELL	RIPTON
BAKERSFIELD	ELMORE	LUNENBURG *	ROCHESTER
BARNARD	ENOSBURG	LYNDON	ROCKINGHAM
BARNET	ENOSBURG FALLS	LYNDONVILLE	ROXBURY
BARRE	ESSEX	MANCHESTER	ROYALTON
BARTON	ESSEX JUNCTION	MARLBORO	RUPERT
BELVIDERE	FAIR HAVEN	MARSHFIELD	RUTLAND
BENNINGTON	FAIRFAX	MENDON	RYEGATE *
BERKSHIRE	FAIRFIELD	MIDDLEBURY	S ROYALTON
BERLIN	FAIRLEE	MIDDLESEX	SALISBURY
BETHEL	FERDINAND	MILTON	SANDGATE
BINGHAMVILLE	FERRISBURG	MONKTON	SAXTONS RIVER
BRADFORD	FLETCHER	MONROE BRIDGE	SEARSBURG
BRAINTREE	GEORGIA	MONTGOMERY	SHAFTSBURY
BRANDON	GLASTENBURY	MONTPELIER	SHARON
BRATTLEBORO	GLOVER	MORETOWN	SHEFFIELD
BRIDGEWATER	GOSHEN	MORGAN	SHELBURNE
BRIGHTON	GRAND ISLE	MORRISTOWN	SHELDON
BROOKFIELD	GRANVILLE	NEW HAVEN	SHERBURNE
BROOKLINE	GREENSBORO	NEWARK	SO BURLINGTON
BROWNINGTON	GUILFORD	NEWBURY *	SOMERSET
BURKE	HALIFAX	NEWFANE	SOUTH HERO
BURLINGTON	HANCOCK	NEWPORT	SOUTH STRAFFORD
CALAIS	HARDWICK	NEWPORT TOWN	ST ALBANS
CAMBRIDGE	HARTFORD	NORTH HERO	ST GEORGE
CASTLETON	HARTLAND	NORWICH *	ST JOHNSBURY
CAVENDISH	HIGHGATE	ORANGE	STANNARD
CHARLOTTE	HOLLAND	ORLEANS	STOCKBRIDGE
CHELSEA	HYDE PARK	PANTON	STOWE
CHITTENDEN	IRA	PEACHAM	STRAFFORD
CLARENDON	IRASBURG	PERU	STRATTON
COLCHESTER	ISLAND POND	PITTSFIELD	SUDBURY
CONCORD	JACKSONVILLE	PITTSFORD	SUNDERLAND
COVENTRY	JAMAICA	POMFRET	SUTTON
DANVILLE	JAY	POULTNEY	SWANTON
DERBY	JEFFERSONVILLE	POWNA	THETFORD *
DORSET	JERICO	PROCTOR	TOWNSHEND
DOVER	JOHNSON	PUTNEY	TROY
DUMMERSTON	KIRBY	RANDOLPH	TUNBRIDGE
DUXBURY	LANDGROVE	READING	UNDERHILL

Vermont Continued...

VERGENNES
VERNON
VERSHIRE
VICTORY *
WALDEN
WALTHAM
WARDSBORO
WASHINGTON
WATERBURY
WATERFORD

WATERVILLE
WEATHERSFIELD
WELLS
WEST BURKE
WEST FAIRLEE
WEST HAVEN
WEST LEBANON
WEST RUTLAND
WEST WINDSOR
WESTFIELD

WESTFORD
WESTMINISTER *
WESTMORE
WESTON
WHEELOCK
WHITINGHAM
WILLISTON
WILMINGTON
WINDHAM
WINDSOR

WINHALL
WINOOSKI
WOLCOTT
WOODBURY
WOODFORD
WOODSTOCK
WORCESTER

also Includes...

CHARLESTON, NH *
CHESTERFIELD, NH *
CORNISH, NH *
HINSDALE, NH
LEBANON, NH *
LYME, NH *
MONROE, NH *

ORFORD, NH
PIERMONT, NH *
PLAINFIELD, NH *
WALPOLE, NH *
MONROE BRIDGE, MA
HAMPTON, NY
LOW HAMPTON, NY

APPENDIX IV

Index of License Application Forms

Application and Pole Attachment License	1
Authorization for Field Survey Work	2
Itemized Pole Make-Ready Work and Charges	3
Authorization for Pole Make-Ready Work	4
Licensee Itemized Self Survey	5
Notification of Discontinuance of Use of Poles	6
Project Management Request	7
Licensee to RCE Notification	8
Power Supply Schematic	10

Form 1
APPLICATION AND POLE ATTACHMENT LICENSE

Licensee FREEDOM RING COMMUNICATIONS, LLC. d/b/a Bayring
Communications
Street Address _____
City, State and Zip _____
Date _____

In accordance with the terms and conditions of the Pole Attachment Agreement, application is hereby made for a license to make _____ attachments to poles and _____ Power Supply(ies) and _____ other attachments located in the municipality of _____ in the State of _____.

This request will be designated Pole Attachment License Application Number _____. Attached are my power supply specifications if applicable. The cable's strand size is _____ and weight per foot of cable is _____.

Licensee's Name (Print) _____

Signature _____

PUBLIC SERVICE COMPANY OF NEW HAMPSHIRE
Power Company Title _____

Tel. No. _____

Fax No. _____

E-mail _____

*****For licensor use, do not write below this line*****

Pole Attachment License Application Number _____ is hereby granted to make the attachments described in this application to attachments to JO¹ poles, _____ attachments to FO² poles, _____ attachments to JU³ poles, _____ Power Supplies and _____ other attachments located in the municipality of _____, in the State of _____ as indicated on the attached

Form 3.

Licensor's Name (Print) _____

Signature _____

(AGREEMENT ID #) Title _____

Date _____

Tel. No. _____

FORM 1 INSTRUCTIONS

Individual applications to be numbered in sequential ascending order by Licensee for each Pole Attachment License. Licensor will process applications in sequential ascending order according to the application numbers assigned by the Licensee.

◆ Provide a separate application for each municipality
Note: (For municipalities served by more than one Power Company a separate application for each Power Company area must be provided.)

◆ Limit the number of poles to 200 per each application

◆ Attach power supply specifications

◆ Provide the size of your cable strand

◆ Provide the Weight per foot of cable

◆ Other Attachments (Include Riser Information here)

(1) JO = Jointly Owned - a pole in which Verizon New England Inc. has an ownership interest.

(2) FO = Fully Owned/Solely Owned – a pole that is solely owned by Verizon New England Inc. or the Power Company.

(3) JU = Joint Use – A party to whom use of the pole or anchor has been extended by the owner of the facility. The term “Joint User” shall not include Licensees.

The Licensee shall submit an original copy of this application to Verizon New England Inc. and the appropriate Power Company.

Revised 10/15/03

AUTHORIZATION FOR FIELD SURVEY WORK

Licensee: FREEDOM RING COMMUNICATIONS, LLC. d/b/a Bayring Communications

In accordance with Article III & Appendix I of the Pole Attachment Agreement, following is a summary of the charges which will apply to complete a field survey covering Pole Attachment License Application Number _____ in the municipality of _____ in the State of _____.

FIELD SURVEY CHARGES

<u>Field Survey</u>	<u>#Poles</u>	<u>Unit Rate</u>	<u>Total</u>
Field Survey 1-10 Poles	_____	\$ _____	\$ _____
Field Survey 11-200 Poles	_____	\$ _____ per Pole	\$ _____
Additional Travel Time*	_____	\$ _____ per Day	\$ _____
TOTAL Charges			\$ _____

* Based on average of 75 poles surveyed per day, add \$200.00 travel time for each additional day required to complete survey.

Please note, if you calculated the cost incorrectly, your check will be returned and a new check for the correct amount must be received by this office in order to schedule the survey. If you need assistance, please call the **HOTLINE on (800) 641-2299**.

The required field survey covering Pole Attachment License Application # _____ is authorized. I am enclosing an advance payment in the amount of \$ _____.

Licensee's Name (Print) _____

Signature _____

Title _____

Address _____

Tel. No. _____

Date _____

FORM 3 - VERIZON ITEMIZED Pole Make-Ready Work Charges
 RCE to Complete: Total Poles Surveyed _____ Total Pole Requiring Verizon Make-Ready _____

Appendix IV Form 3

FIELD SURVEY / MAKE READY WORK FORM														
SURVEYORS:														
Verizon		DATE OF SURVEY:		CWO #:		MUNIC:		STATE:		Exch Code:		Munic Code:		
Licensee		LICENSEE NAME:		LICENSEE NAME:		LICENSEE APPLICATION #:		LICENSEE APPLICATION #:		LICENSEE APPLICATION #:		LICENSEE APPLICATION #:		
ELCO		ELCO NAME:		ELCO NAME:		ELCO NAME:		ELCO NAME:		ELCO NAME:		ELCO NAME:		
LOCATION		POLE #		ATT		OWNERSHIP		CHARGE		WORK DESCRIPTION		* Height of Att.		
TEL RTE / STREET NAME <i>List one pole per line</i>	Tel	El	F/C	P.S. <i>Riser</i>	J.O.		J.U.		F.O.		YES	NO	TASK #S / REMARKS	* Height of Att.
					Tel	El	Tel	El	Tel	El				
TOTALS:														

• Height of Attachment = Height of Licensee Attachment shall be 40" below ELCO MGN unless otherwise noted here by Verizon and ELCO surveyor.
 • Licensee to complete **bold italicized areas only.** (Provide ownership information if known.)

SURVEYORS: Name of Representative attending Survey from VERIZON, Power Company and Licensee

Date of Survey : Date Survey is performed

CWO#: Verizon's Custom Work Order Number

Munic: Municipality where pole is located **State:** State in which pole is located

Licensee Name: Name of Company or Entity applying for Pole Attachments

Exch Code: Verizon's Exchange Code = the Exchange in which the Municipality is located.

Munic Code: Verizon's Municipality Code = the code for the Municipality in which the pole is located (tax purposes).

Application #: The number of the Licensee's Application = sequentially numbered by municipality.

ELCO NAME: The name of the Electric (power) Company in whose service area the pole is located.

Location: List each individual pole (ONE POLE PER LINE) you wish to attach to (multiple sheets may be used) and provide the following:

Street, Route, Circuit # and other information which indicates location of poles.
Indicate location by providing name of street, highway, route, etc., e.g., South Street, north of (N/O) Jones Road. Private Property Poles should be identified as such e.g., P.P. (Lead off pole 1234 South).

Pole #: Tel = Telephone Company pole # El= Electric Company pole #

ATT: Type of Attachment: F = Fiber C= Copper or Coaxial P.S. = Power Supply Riser = Riser Pole

Ownership: JO = Joint Owned 50%-50% Tel-Elco, JU = Joint Use - 100% Tel or 100% Elco, FO = 100% Fully owned by Tel or Elco (Other company not on pole)

Charge: Y or N = Y = Yes, there are make ready charges, N = No, there are no make ready charges to the Applicant.

Work Description: Short description of work operations required.

Task # should also be included and is defined as the number of the task or tasks required for make ready work. The Task # is associated with a Unit Price from the "Make Ready Unit Price Schedule" located in Appendix 1 of the new Pole Attachment Agreement.

Form 4

AUTHORIZATION FOR POLE MAKE-READY WORK

Licensee FREEDOM RING COMMUNICATIONS, LLC. d/b/a Bayring
 Communications

Field survey work associated with your License Application No. _____ dated
 _____, for attachment to poles, in the municipality of _____,
 State of New Hampshire has been completed. Following is a summary of the make-ready
 charges which will apply:

<u>TASK #</u>	<u>QUANTITY</u>	<u>UNIT COST</u>	<u>TOTAL COST</u>
Custom Work Order Preparation			
Miscellaneous			

Attached, as requested, is an itemized unit cost (Form 3) of required make-ready work
 and associated charges. If you wish us to complete the required make-ready work, please
 sign this copy below and return with an advance payment in the amount of
 \$ _____.

Licensor's Name (Print) _____

Signature _____

Title _____

Address _____

Tel. No _____

Date _____

The replacements and rearrangements included in Pole Attachment License Application
 No. _____ are authorized and the costs therefore will be paid to Licensor in
 accordance with Appendix I to Pole Attachment License Agreement. My check is
 attached.

Licensee's Name (Print) _____

Signature _____ Tel. _____

Title _____ Date _____

FORM 5 LICENSEE SELF-SURVEY FORM Definitions

SUMMARY- The total number of poles surveyed and the total number of poles requiring Verizon Make-Ready

SURVEYORS: Name of Representative attending Survey from VERIZON, Power Company and Licensee

Date of Survey : Date Survey is performed

CWO#: Verizon's Custom Work Order Number

Munic: Municipality where pole is located **State:** State in which pole is located

Licensee Name: Name of Company or Entity applying for Pole Attachments

Exch Code: Verizon's Exchange Code = the Exchange in which the Municipality is located.

Munic Code: Verizon's Municipality Code = the code for the Municipality in which the pole is located (tax purposes).

Application #: The number of the Licensee's Application = sequentially numbered by municipality.

ELCO NAME: The name of the Electric (power) Company in whose service area the pole is located.

Location: List each individual pole (**ONE POLE PER LINE**) you wish to attach to (multiple sheets may be used) and provide the following:

Street, Route, Circuit # and other information which indicates location of poles.
Indicate location by providing name of street, highway, route, etc., e.g., South Street, north of (N/O) Jones Road. Private Property Poles should be identified as such e.g., P.P. (Lead off pole 1234 South).

Pole #: Tel = Telephone Company pole # El= Electric Company pole #

ATT: Type of Attachment: F = Fiber C= Copper or Coaxial P.S. = Power Supply Riser = Riser Pole

Ownership: JO = Joint Owned 50%-50% Tel-Elco, JU = Joint Use - 100% Tel or 100% Elco, FO = 100% Fully owned by Tel or Elco (Other company not on pole)

Charge: Y or N = Y = Yes, there are make ready charges, N = No, there are no make ready charges to the Applicant.

Work Description: Short description of work operations required.

Task # should also be included and is defined as the number of the task or tasks required for make ready work. The Task # is associated with a Unit Price from the "Make Ready Unit Price Schedule" located in Appendix 1 of the new Pole Attachment Agreement.

Form 6

NOTIFICATION OF DISCONTINUANCE OF USE OF POLES

This form is to be completed and mailed to Verizon New England Inc., LICENSE ADMINISTRATION at the address listed below and the appropriate Power Company:

**Verizon New England Inc.
LICENSE ADMINISTRATION
185 Franklin Street, Room 503
Boston, Massachusetts 02110**

Licensee FREEDOM RING COMMUNICATIONS, LLC. d/b/a Bayring
Communications
Street Address 359 Corporate Dr.
City and State Portsmouth, NH Date _____

In accordance with the terms of Pole Attachment License Agreement dated _____, this serves as written notification from Licensee that attachment(s) to the following pole(s) in the municipality of _____, State of _____, are being discontinued (removed) on _____.
These attachments are covered by Pole Attachment License Application number _____.

<u>Pole Number</u>	<u>Location</u>	<u>Attachment</u>
_____	_____	_____
_____	_____	_____
_____	_____	_____
_____	_____	_____
_____	_____	_____
_____	_____	_____
_____	_____	_____

Total number of attachments to JO¹ poles to be discontinued _____.
Total number of attachments to FO² poles to be discontinued _____.
Total number of attachments to JU³ poles to be discontinued _____.
Total number of Power Supplies/Other Equipment to be discontinued _____.

Said license is to be canceled **in its entirety / partially** as above.
(circle one)

Licensee _____ Print Name _____

Signature _____ Tel. No. _____ Fax No. _____

Title _____ Date _____

APPLICATION # _____

LICENSEE
NAME _____

MUNICIPALITY _____ STATE _____

To be completed by Licensor :

It has been verified by Licensor that the number of attachments to be discontinued have been removed from Licensor's poles and the number of attachments have been adjusted as appropriate on the preceding page.

VERIZON New England Inc.

VERIZON Representative (Print Name) _____

Signature _____ Title _____

Tel. No. _____ Date: _____

- (1) JO = Jointly Owned - a pole in which Verizon New England Inc. has an ownership interest.
- (2) FO = Fully Owned/Sole Owned – a pole that is solely owned by Verizon New England Inc.
- (3) JU = Joint Use – A party to whom use of the pole or anchor has been extended by the owner of the facility. The term “Joint User” shall not include Licensees.



Verizon New England Inc.
FORM 8

Licensee To RCE Notification Form

Licensee Name: _____

Municipality: _____

State: _____ VZ Application # _____

This is to notify you that the facilities (cables, power supplies) have been placed in association with License Application # _____ on _____ 200_.

This is to notify you that an overlash project has been Started Completed (*choose one*) in association with License Application # _____ on _____ 200_.

This is to notify you that a rebuild project has been completed in association with License Application # _____ on _____ 200_.

This is to notify you that a pre-construction survey is necessary for the poles listed on the attached Form 5 requiring Verizon Make-Ready work.

FAX to RCE :

Call the LAG Hotline at 800-641-2299 for appropriate RCE name and fax number.

LICENSEE POWER SUPPLY SCHEMATIC

(LICENSEE MUST SUBMIT ONE FORM 10 FOR EACH POWER SUPPLY LOCATION)

FORM 10 Request STAFF-01

Dated: 09/07/2012

Attachment 6

REVISID 05/21/02 Page 78 of 89

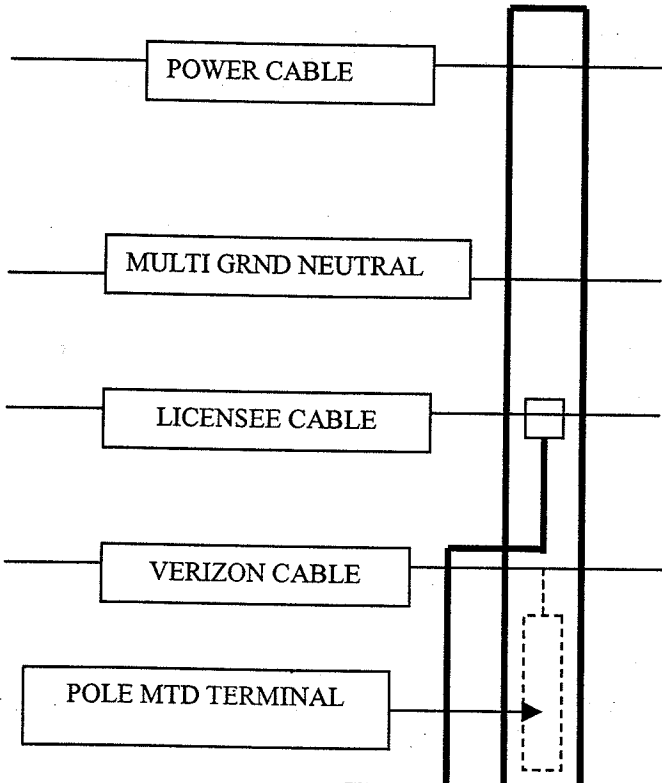

LICENSEE NAME: _____
 APPLICATION # _____
 STREET NAME: _____
 TEL ROUTE # _____
 TEL POLE # _____ ELCO POLE # _____
 MUNI: _____ STATE: _____
 ELCO NAME: _____

POWER SUPPLY CABINET MUST BE ATTACHED WITH BRACKETS WHICH ALLOW MINIMUM 3 INCHES CLEARANCE BETWEEN POLE AND CABINET.

PROPOSED POWER SUPPLY CABINET DIMENSIONS:

MAKE= _____
 MODEL= _____
 HEIGHT= _____ IN
 WIDTH= _____ IN
 DEPTH= _____ IN
 WEIGHT= _____ LBS

MINIMUM CLEARANCE = 31 INCHES

TOP OF POWER SUPPLY CABINET = _____ FT _____ IN

INDICATE P.S. LOCATION BY SHADING IN QUADRANT

ROADSIDE

FIELD SIDE

NOTE: POWER SUPPLY MUST BE MOUNTED ON QUADRANT OPPOSITE EXISTING VERIZON POLE MOUNTED TERMINAL

POLE DATA

POLE HEIGHT= _____ FT
 POLE CLASS= _____
 POLE CONDITION* _____
 *GOOD, FAIR, POOR

MINIMUM GROUND CLEARANCE AS PER APPLICABLE NESC REQUIREMENTS BASED ON POLE LOCATION

NOTE:

LICENSEE MUST HAVE CURRENTLY APPROVED ELECTRIC COMPANY POWER SUPPLY INSTALLATION SCHEMATIC FILED WITH VERIZON PRIOR TO SUBMITTING ITS POWER SUPPLY ATTACHMENT APPLICATION.

GROUND LEVEL

APPENDIX V
Procedure for Rebuilding of Existing Licensee's Aerial Attachments
(Commonly known as Rebuild)

1 – SCOPE

In the process of replacing its existing facilities, it may be necessary for the Licensee to conduct a Rebuild project that may involve placing new facilities while keeping existing facilities in operation.

2 - DEFINITIONS

- a) **Rebuild** – the act of a Licensee replacing existing facilities, for other than maintenance purposes, accomplished in the following manner:
 - 1) The lowering or raising of facilities by a Licensee to a temporary location thereby clearing previously licensed space for a new installation.
 - 2) The placement and activation of new facilities by a Licensee that replace existing Licensee facilities.
 - 3) The transfer of a Licensee's existing customer facilities to Licensee's new facilities being placed.
 - 4) The de-activation and removal of Licensee's replaced facilities.

- b) **Post-construction Inspection** - A Verizon New England Inc. inspection consisting of a ten (10) percent sample of the poles after completion of Licensee's Rebuild project. Licensee shall pre-pay Verizon New England Inc. for the Post-construction Inspection based on the Unit Pricing Schedule.

- c) **Post-construction Subsequent Inspection** – An inspection, subsequent to the Post-construction Inspection, required as the result of finding greater than 2% non-compliance after the Post-construction Inspection of the 10% sample performed by Verizon New England Inc.. Licensee shall prepay Verizon New England Inc. for the Post-construction Subsequent Inspection based on the Unit Pricing Schedule.

- d) **Self Pre-survey**– The performance of a field review by a Licensee to survey the routing of a proposed path where the Rebuild project is planned, to determine if any Make-ready Work is required. The Licensee shall adhere to all requirements of the most recent edition of the National Electrical Safety Code (NESC) and the "Manual of Construction Procedures" (Blue Book), published by Telcordia Technologies Inc. This survey is performed without the presence of a Verizon New England Inc. representative and the results of the Self Pre-survey shall be provided to the Verizon New England Inc. Reimbursable Construction Engineer (RCE) with documentation of any Subsequent Make-ready Work required before Licensee begins construction of the Rebuild project.

- e) **Subsequent Make-ready Work** – Rearrangement of Verizon New England Inc.'s facilities by Verizon New England Inc. as determined by the Licensee's Self Pre-survey to provide for clearance and separation requirements for all pole attachments relative to the latest edition of the Blue Book published by Telcordia and the latest edition of the NESCS.

- f) **Charges** – Verizon New England Inc.'s costs in the Unit Pricing Schedule, based on current Verizon New England Inc. unit pricing methodology, for any Post-construction Inspections, Post-construction Subsequent Inspections and Subsequent Make-ready Work performed by Verizon New England Inc. and paid for in advance to Verizon New England Inc. by the Licensee.

3 – SPECIFICATIONS

Licensee shall conform to the terms and conditions contained within the Specifications Section of the most current Pole Attachment Agreement, including:

The National Electrical Safety Code (NESC)

“Manual of Construction Procedures” (Blue Book), published by Telcordia Technologies Inc.

4 - NOTIFICATION

Licensee shall provide ten (10) days advance notice in writing (Form 8) to the Verizon New England Inc. RCE and coordinate its Rebuild work with the local Verizon New England Inc. RCE and construction coordinator to avoid any scheduling conflicts with any Verizon New England Inc. construction or maintenance work. Licensee shall submit written notification (Form 8) within thirty (30) days to Verizon New England Inc. RCE after their Rebuild work has been completed. Verizon New England Inc. RCE will facilitate the Post-construction Inspection.

5 – PROCEDURES

- a) Upon receipt of notification from Licensee of a planned rebuild, Verizon New England Inc. RCE will initiate and Licensee shall attend a local meeting with Verizon New England Inc. engineers to discuss construction schedules, Self Pre-survey, Pre-construction Survey, and Post-construction Inspections.
- b) Licensee shall provide Verizon New England Inc. RCE with the following information relative to the Rebuild project:
 - 1) Copies of strand maps indicating those poles where Licensee intends to Rebuild their existing pole attachments.
 - 2) Tension measurements and weight per foot of total facilities that will be attached upon completion of the Rebuild project. (per span average)
- c) Licensee shall perform a Self Pre-survey of all routes included in the Rebuild project and shall provide written results (Form 5) to Verizon New England Inc.'s RCE.
- d) Licensee shall submit a written request (Form 8) to Verizon New England Inc.'s RCE to arrange for a Pre-construction Survey of all locations where Licensee has determined Subsequent Make-ready Work is necessary by Verizon New England Inc. to accommodate Licensee's proposed work. Licensee will submit (Form 12) and an advance payment to Verizon New England Inc. to cover the applicable charges for the Pre-construction Survey.
- e) Licensee shall also notify any other attacher, Joint Owner or Joint User on the pole that may be affected by the Rebuild project.

- f) Verizon New England Inc. RCE shall notify the Licensee of the applicable charges for any type of Make-ready Work (RCETEMP6 and Form 13). Prior to Verizon New England Inc. RCE initiating Make-ready Work, Licensee will forward a check along with a signed (Form 13), to Verizon New England Inc. RCE covering Subsequent Make-ready Work charges.
- g) Verizon New England Inc. RCE will provide the Licensee with an associated work schedule and estimated construction completion date for the Make-ready Work via (RCETEMP7).
- h) Licensee may proceed to conduct the Rebuild project in sections of aerial facilities requiring no Make-ready Work. Licensee shall not perform any Rebuild work until the necessary Make-ready Work has been completed by Verizon New England Inc..
- i) Licensee shall notify Verizon New England Inc., in writing (Form 8), that the Rebuild project has been completed.
- j) Within ninety (90) days of receipt of (Form 8) notifying Verizon New England Inc. of completion of Rebuild Project, Verizon New England Inc. may perform a Post-construction Inspection consisting of a ten (10) percent sample of the poles included in the Licensee's Rebuild project. Upon receipt of (Form 9 PCI and RCETEMP4), Licensee, shall pre-pay Verizon New England Inc. for the Post-construction Inspection.
 - 1) If Verizon New England Inc. performs a Post-construction Inspection and all work is in compliance with the requirements and specifications, no further inspection will be required. Verizon will provide the Licensee with the results of the inspection (Form 5 and Form 9 PCI) within thirty (30) days.
 - 2) If Verizon New England Inc. performs the Post-construction and all work is not in compliance on two (2) percent or more of the ten (10) percent sample inspected, Verizon New England Inc. may perform and bill Licensee for a complete Post-construction Subsequent Inspection of all poles involved in the Rebuild project. Verizon New England Inc. will provide Licensee with the results of the inspection via (Form 11 and Form 9 SI) within thirty (30) days in order that the Licensee may bring its facilities into compliance.
 - 3) Verizon New England Inc. may revoke Licensee's right to conduct Self Pre-surveys for future Rebuild projects if more than 2% of the 10% pole sample is found to be in non-compliance.
- k) If the results of the Post-construction Subsequent Inspections show results that are in non-compliance with the aforementioned requirements and specifications, Licensee shall correct such non-conforming condition within thirty (30) days of written notification (Form 9 SI) from Verizon New England Inc. RCE.
- l) Where Licensee fails to correct the stated non-conforming condition within thirty (30) days, Verizon New England Inc. may revoke Licensee's right to perform Rebuild Self Pre-survey and Licensee shall be responsible for any costs associated with correcting such non-conforming conditions.

APPENDIX VI

Procedure for Placing an Additional Licensee's Cable on Same Licensee's Previously Licensed Aerial Pole Attachments (Commonly Known as Overlash)

1 – SCOPE

In the process of upgrading cable plant capacity, it may be necessary for the Licensee to augment the number of its cables and equipment lashed or attached to its existing strand.

2 - DEFINITIONS

- a) **Overlash** – The act of attaching any single strand, hardware, cable, wires and/or apparatus owned by Licensee to same Licensee's existing strand, hardware, cable, wires and/or apparatus.
- b) **Post-construction Inspection** - A Verizon New England Inc. inspection of the poles after completion of Licensee's Overlash project at its own cost except that Licensee shall pay Verizon New England Inc. for the inspection of those poles found not in compliance as a result of the Inspection.
- c) **Post-construction Subsequent Inspection** – An inspection, subsequent to the Post-construction Inspection, required as the result of finding poles in non-compliance after the Post-construction Inspection performed by Verizon New England Inc. Licensee shall prepay Verizon New England Inc. for the Post-construction Subsequent Inspection based on the Unit Pricing Schedule.
- d) **Self Pre-survey**– The performance of a field review by a Licensee to survey the routing of a proposed path where additional overlashed cable facilities are planned, to determine if any Make-ready Work is required. The Licensee shall adhere to all requirements of the most recent edition of the National Electrical Safety Code (NESC) and the "Manual of Construction Procedures" (Blue Book), published by Telcordia Technologies Inc.. This survey is performed without the presence of a Verizon New England Inc. representative and the results of the Self Pre-survey shall be provided to the Verizon New England Inc. Reimbursable Construction Engineer (RCE) with documentation of any Subsequent Make-ready Work required before Licensee begins construction of the Overlash project.
- e) **Subsequent Make-ready Work** – Rearrangement of Verizon New England Inc. facilities by Verizon New England Inc. as determined by the Licensee's Self Pre-survey to provide for clearance and separation requirements for all pole attachments relative to the latest edition of the Telcordia Blue Book and the latest edition of the NESC.

- f) **Charges** – Verizon New England Inc. 's costs in the Unit Pricing Schedule, based on current Verizon New England Inc. unit pricing methodology.

3 – SPECIFICATIONS

Licensee shall conform to the terms and conditions contained within the Specifications Section of the most current Pole Attachment Agreement, including:

The National Electrical Safety Code (NESC)

Part 2 Section 26-261K2 Strength Requirements.

Part 2 Section 25-250 Loading Requirements

“Manual of Construction Procedures” (Blue Book), published by Telcordia Technologies Inc.

Section 4.2 Table 4 – 1 and Note 2

Section 3 Clearances

4 - NOTIFICATION

- a) Licensee shall provide 5 days advance notice, in writing (Form 8), to the Verizon New England Inc. RCE prior to their Overlash work being started. Licensee will coordinate its Overlash work with the local Verizon New England Inc. RCE and construction coordinator to avoid any scheduling conflicts with any Verizon New England Inc. construction or maintenance work.
- b) Licensee shall submit written notification (Form 8) within thirty (30) days to the Verizon New England Inc. RCE after their Overlash work has been completed, to enable the Verizon New England Inc. RCE to facilitate the post-construction inspection.

5 – PROCEDURES

- a) Licensee shall perform a Self Pre-survey of all routes where it proposes to Overlash cable to its existing licensed facility and provide written results (Form 5) to the Verizon New England Inc. RCE.
- b) Licensee will submit a written request (Form 8) to Verizon New England Inc RCE to arrange for a Pre-construction Survey of all locations where Licensee has determined Subsequent Make-ready Work is necessary by Verizon New England Inc. to accommodate Licensee's proposed work. Licensee will submit Form 12 and an advance payment to Verizon New England Inc. to cover the applicable charges for the Pre-construction Survey.
- c) Verizon New England Inc. RCE will notify the Licensee of the applicable charges for any type of Make-ready Work via (RCETEMP6 and Form 13).
- d) Licensee will submit a signed (Form 13) and a check covering Make-ready work charges.
- e) Verizon New England Inc. RCE will provide the Licensee with an associated work schedule and estimated construction completion date for the Make-ready Work via (RCETEMP7).

- f) Licensee may proceed to place the overlashed cable in sections of aerial facilities requiring no Make-ready Work. Licensee may proceed to place the overlashed cable in sections of aerial facilities requiring Make-ready Work when all parties affected concur that a non-compliance will either be corrected by the Licensee concurrently with the Overlash project, or by any other attacher, Joint Owner or Joint User after the Overlash project has been completed.
- g) Licensee shall notify Verizon New England Inc. in writing (Form 8) that the Overlash project has been completed. Verizon New England Inc. may perform a Post-construction Inspection of the poles included in the Licensee's Overlash project within ninety (90) days of receipt of (Form 8).
 - 1) If Verizon New England Inc. performs a Post-construction Inspection of the poles involved in the Licensee's Overlash project and all work is in compliance with the requirements and specifications, the cost of the inspection will be borne by Verizon New England Inc. and no further Post-construction Inspection will be required. Verizon will provide the Licensee with the written results of the inspection (Form 11 and Form 9PCI) within thirty (30) days.
- h) If Verizon New England Inc. performs the Post-construction Inspection of the poles involved in the Licensee's Overlash project and determines that Licensee's work is not in compliance, Licensee will pay Verizon New England Inc. for the inspection of those poles found in noncompliance. Verizon will provide the Licensee with the charges for the inspection via (RCETEMP 4). In addition, Verizon New England Inc. may perform and Licensee will prepay for the Post-construction Subsequent Inspection of those poles found to be in noncompliance in order to ensure that the Licensee has brought its facilities into compliance. Verizon New England Inc. will provide Licensee with the results of the inspection, (Form 11 and Form 9 SI), within thirty (30) days of the inspection in order that the Licensee may bring its facilities into compliance.
- i) Verizon New England Inc. will continue to conduct Post-construction Subsequent Inspections until all of Licensee's facilities as a result of the Overlash project have been made compliant. If the results of the Post-construction Subsequent Inspections show results that are in non-compliance with the aforementioned requirements and specifications, Licensee shall correct such non-conforming condition within thirty (30) days of written notification (Form 9 SI) from Verizon New England Inc. RCE. Where Licensee fails to correct the stated non-compliant condition within thirty (30) days, Verizon New England Inc. may revoke Licensee's right to perform Overlash Self Pre-survey and Licensee shall be responsible for any costs associated with correcting such non-compliant conditions.

Issued - December 11, 2001

APPENDIX VII

Procedure for Obtaining an Attachment License for the Installation of Power Supplies

1 - SCOPE

In the process of providing or upgrading service, it may be necessary for a Licensee to place power supplies requiring a Pole Attachment License.

2 - DEFINITIONS

- a) **Power Supply** – Any of Licensee’s facilities in direct contact with or supported by a utility pole including a piece of equipment, cabinet, or associated apparatus for the purpose of providing power for Licensee’s facilities, with the exception of any cable attachments.
- b) **Self Pre-survey** - The performance of a field review by a Licensee to survey the pole locations where proposed Power supplies are planned to determine if any Make-ready Work is required. The Licensee shall adhere to all requirements of the most recent edition of the National Electrical Safety Code (NESC) and the “Manual of Construction Procedures” (Blue Book), published by Telcordia Technologies Inc.. This survey is performed without the presence of a Verizon New England Inc. representative and the results of the Self Pre-survey shall be provided to the Verizon New England Inc. License Administration Group (LAG) with documentation of any Make-ready Work required before Licensee begins any work relative to placement of the Power Supply.

3 - SPECIFICATIONS

Licensee shall conform to the terms and conditions contained within the Specifications Section of the most current Pole Attachment Agreement, including:

The National Electrical Safety Code (NESC)

**“Manual of Construction Procedures” (Blue Book), published by
Telcordia Technologies Inc. - Section 13**

4 - APPLICATION

Licensee shall provide Verizon New England Inc. with a completed Pole Attachment License Application for all pole locations where it proposes to make its Power Supply attachments. Licensee shall also include a completed Licensee Power Supply Schematic - Form 10 for each pole location on its License Application. In addition, the Licensee shall provide the following information:

- a) An approved Power Company Power Supply installation diagram and associated specifications must be included if not already on file with Verizon New England Inc.'s Reimbursable Construction Engineer (RCE). Verizon

New England Inc.'s RCEs will retain this master copy for each individual power company.

Licensee is responsible for updating this information as installation diagrams and specifications change.

- b) If pole Make-ready Work is required, Licensee shall submit a separate application listing those locations in need of Make-ready Work, along with a check to Verizon New England to cover the cost of a field survey using the unit cost pricing schedule.
- c) Licensee shall not place any Power Supply until Licensee has received a Pole Attachment License for the pole location identified in the Application for the Pole Attachment License.

5 – PROCEDURE

The following procedure shall be followed when Licensees perform Self Pre-surveys for Power Supplies:

- a) Licensee shall perform a Self Pre-survey of all poles where it proposes to place Power Supplies.
- b) Licensee shall submit a Pole Attachment License Application consisting of Form 1, Form 5, and Form 10 for those poles where no Make-ready Work is required to place a Power Supply as a result of the Self Pre-survey. Verizon New England LAG will then issue the Pole Attachment License for the Licensee's Power Supply.
- c) Licensee shall submit a Pole Attachment License Application consisting of Form 1, Form 2, Form 4, Form 5 and Form 10 to Verizon New England Inc.'s LAG to arrange for a Pre-construction Survey of all locations where Licensee has determined Make-ready Work is required by Verizon New England as a result of the Self Pre-survey to accommodate Licensee's proposed work.
 - 1) Licensee will issue an advance check to the Verizon New England LAG to cover the applicable charges for the Pre-construction Survey.
 - 2) Upon receipt of the check for the Pre-construction Survey the Verizon New England RCE will contact the power company and the Licensee to arrange a date for a field survey. The survey will be performed to determine the scope of Make-ready Work necessary to provide the required clearances for the Licensee's Power Supply.
 - 3) Upon completion of the field survey, Verizon New England LAG shall notify the Licensee via Form 4 of any Make-ready Work charges. The Licensee shall submit to the LAG an advance check and a signed Form 4 prior to Verizon New England Inc. commencing any Make-ready Work.
 - 4) Upon receipt of the check for the Make-ready Work the Verizon New England LAG will provide the Licensee with an associated work schedule and estimated construction completion date for the Make-ready Work.
 - 5) Once all required Make-ready Work has been completed, Verizon New England LAG will then issue the Pole Attachment License for the Licensee's Power Supply.

- d) Licensee shall submit written notification (Form 8) within 30 (thirty) days to Verizon New England Inc. RCE after their Power Supply attachments have been completed.
- e) Verizon New England may perform a Post-construction Inspection of the poles included in the Licensee's Power Supply project within 90 (ninety) days of receipt of Form 8. Upon Receipt of Form 9 PCI and RCETEMP4, Licensee shall pre-pay Verizon New England for the Post-construction Inspection.
 - 1) If Verizon New England performs a Post-construction Inspection and all work is in compliance with the requirements and specifications, no further inspection will be required. Verizon will provide the Licensee with the results of the inspection (Form 5 and Form 9 PCI) within 30 (thirty) days.
 - 2) If Verizon New England Inc. performs the Post-construction Inspection and determines that any of Licensee's Power Supply work is not in compliance with Section 3 Specifications, Verizon New England Inc. will provide Licensee with the results of the inspection via Form 11 and Form 9 SI within 30 (thirty) days in order that the Licensee may bring its facilities into compliance.
 - 3) Verizon New England Inc. will continue to conduct Post Construction Subsequent Inspections until all of Licensee's facilities as a result of the Power Supply project have been made compliant. Licensee shall prepay Verizon New England for the cost of performing all Subsequent Inspections. If the results of the Post Construction Subsequent Inspections show results that are in non-compliance with the requirements and specifications, Licensee shall correct such non-conforming condition within 30 (thirty) days of written notification from Verizon New England Inc. RCE. Verizon New England Inc. RCE will provide Licensee with the results of the Subsequent Inspections via Form 11 and Form 9 SI to allow the Licensee to bring its facilities into compliance.
- f) Licensee shall correct any non-conforming condition within thirty (30) days of written notification from Verizon New England. Where Licensee fails to correct stated non-conforming condition within thirty (30) days, Verizon New England may revoke Licensee's future right to perform Self Pre-survey of Power Supplies. Licensee shall be responsible for any costs associated with correcting such non-conforming conditions.
- g) If at anytime in the future, following the attachment of a Power Supply, Verizon New England requests the Licensee to either reconfigure its equipment, or locate to a new pole, the Licensee agrees to perform this work within thirty (30) days of any such request at the Licensee's expense.
- h) No Power Supply construction shall take place on any pole requiring Make-ready Work until any such work has been paid for in advance, completed by Verizon New England, and the Licensee has been notified of its completion by Verizon New England.

- i) If a Power supply is placed before a license is issued, its presence shall be considered as unauthorized and charges shall be as specified for unauthorized attachments in ARTICLE IX – UNAUTHORIZED ATTACHMENTS in the POLE ATTACHMENT AGREEMENT.

APPENDIX VIII

Job Aid For Requests To Records

In an effort to maintain consistency associated with requests from outside VERIZON NEW ENGLAND INC. for the viewing or securing of Conduit Plats this job aid is being prepared.

REQUESTS

The process begins with the request from the customer to the RCE (Reimbursable Construction Engineer), which may be directed to the Design Administrator Group for the specific area where the request is made.

The request must be submitted in writing, indicating what the customer requires (usually a map which has been highlighted or a listing of streets, etc. is supplied by the customer) along with a reason for the request.

Verizon New England Inc. will make the conduit records available within a reasonable time frame (normally five day turn around) upon receipt of the **written request**, for the specific areas mentioned in the letter. As VERIZON NEW ENGLAND INC. does not maintain all plats it may be necessary to secure the specific drawings from our vendors and the customer should be informed of any delay this may cause.

CHARGES & BILLING

The Design Administrator, if involved, will secure a Keep Cost Number from the area Reimbursable Construction Engineer for each new customer request or for each municipality which is submitted for conduit plats when it is determined the requestor is to be charged. When a job number is secured the job can remain open for six months (January through June, July through December) and should be used for subsequent requests from the same customer or municipality.

VERIZON NEW ENGLAND INC. does plan swaps with the Electric Companies when the information required is for electrical purposes. If the customer is a municipality – there is no charge. These types of requests however must still follow the written request procedures.

Based on analysis of time and material it has been determined a charge of \$7.50 per plat with a minimum charge of \$25.00 is to be used in determining costs.

Up-front payment is required before distribution of any plats.

All checks should be made out to VERIZON NEW ENGLAND INC..

The Design Administrator or RCE will forward any checks to the RPC in Maryland with the advance payment transmittal form. These forms can be secured from the area Reimbursable Construction Engineer.

NON-DISCLOSURE AGREEMENTS

For each request a signed non-disclosure form is required from someone with authority in the organization making the request. A disclaimer at the end of the non-disclosure agreement is to advise the customer that the information they are getting is for preliminary design purposes only – they still need to do field surveys and measurements.

On the second page of the non-disclosure there is a space to enter the price being charged.

There are three Non-Disclosure Agreements as follows:

Non-Disclosure 1 is for use with large controlling entities such as the gas company and electric, MBTA, etc. Use the term plan swap in place of the monetary issue.

Non-Disclosure 2 is for anyone other than those mentioned in 1 and 3 such as licensees, surveyors, engineering firms, etc.

Non-Disclosure 3 is for municipalities.

If there is more than one recipient for the request, please add more RECIPIENTS to the bottom of the non-disclosure so that all involved can sign.

No signature – No records

PROPRIETARY INFORMATION

Normally conduit plats do not contain information that is considered proprietary therefore scrubbing (removal) is not required.

STAMPING OF PLATS

Plats should be stamped indicating "This record is for preliminary design purposes only and does not preclude the need for field survey and measurement." These stamps have been provided to the various Design Administrator and RCE groups.

RELEASE OF INFORMATION

When payment has been received and the non-disclosure agreement signed, the customer may pick-up the requested plats or they can be mailed, based on the customer's preference. The customer also has the option of viewing the plats at our location, following all the steps mentioned previously (written request, up-front payment, signed non-disclosure), which has been the case chosen by some customers.

INTERNAL REQUIREMENT

The Reimbursable Construction Engineer should also be provided copy of all non-disclosure agreements and copies of the advance payment transmittal to retain with the job. These details are required for job closing

The Reimbursable Construction Engineer remains available to assist the Design Administrator in following this procedure.

Utilization of the CONDUIT PLAT REQUEST LOG is mandatory for tracking the details associated with these requests for records and must be maintained for Regulatory purposes.

Pole Record Requests

Access to pole records are not normally received from customers as these structures can be accessed visually however, in the event requests, in writing, for access to pole records is received the RCE will direct the customer to the Design Administrator for the specific area.

A printout of the Pole Record System (PRS) for the specific location would be retrieved; removal of any proprietary information may be required.

The customer would be required to submit payment for the time required accessing and producing the documents (time and material costs). Upon receipt of the check the documents would be given to the customer. No non-disclosure document would be required, as these structures are visible to the public at large.

Right Of Way Requests

Right Of Way documents are a matter of public record and can be obtained from the various State and Municipal Offices such as City / Town Halls, Registry of Deeds, etc.

However, in the event requests are received, in writing, for Right of Way documents by customers the RCE would direct the requesting party to the appropriate Right Of Way Engineer for the area in question.

The customer would be required to submit payment for the time required by the Right Of Way Engineer to locate and produce the documents being requested (time and material costs). Upon receipt of the check the documents would be given to the customer. No non-disclosure sign-off would be necessary, as these documents are available to the public.